

# Installation Instructions

# Refrigerator

Questions? Call 800.GE.CARES (800.432.2737) or visit our Website at: [GEAppliances.com](http://GEAppliances.com)  
In Canada, call 1.800.561.3344 or visit our Website at: [www.GEAppliances.ca](http://www.GEAppliances.ca)

## BEFORE YOU BEGIN

Read these instructions completely and carefully.

- **IMPORTANT** – Observe all governing codes and ordinances. Save these instructions for local inspector's use.
- **Note to Installer** – Be sure to leave these instructions with the Consumer.
- **Note to Consumer** – Keep these instructions for future reference.
- **Skill level** – Installation of this appliance requires basic mechanical skills.
- **Completion time** – Refrigerator Installation  
20 minutes  
Water Line Installation  
30 minutes
- Proper installation is the responsibility of the installer.
- Product failure due to improper installation is not covered under the Warranty.

## PREPARATION

### MOVING THE REFRIGERATOR INDOORS

If the refrigerator will not fit through a doorway, the refrigerator door and freezer drawer or door can be removed.

- To remove the refrigerator door, see Step 1 in the *Reversing the Door Swing* section.
- To remove the freezer drawer, see the *Removing the Freezer Drawer* section.

### WATER SUPPLY TO THE ICE MAKER AND DISPENSER

If the refrigerator has an ice maker, it will have to be connected to a cold water line. A GE water supply kit (containing tubing, shutoff valve, fittings and instructions) is available at extra cost from your dealer, by visiting our website at [GEAppliances.com](http://GEAppliances.com) (in Canada at [www.GEAppliances.ca](http://www.GEAppliances.ca)) or from Parts and Accessories, 800.626.2002 (in Canada 1.800.661.1616).

## TOOLS YOU MAY NEED



Adjustable Wrench

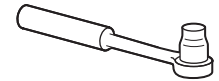

3/8" and 5/8" Socket Ratchet/Driver

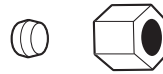

1/4" Outer Diameter Compression Nut and Ferrule (sleeve) (ice maker models only)

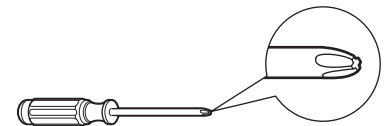

Phillips-Head Screwdriver



3/32", 1/8" & 3/16" Allen Wrenches

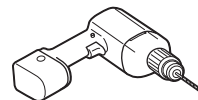

1/8" Drill Bit and Electric or Hand Drill

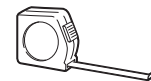

Tape Measure



Pencil



1/4" Nut Driver



Wire Cutters



Level

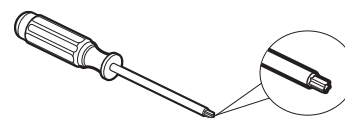

Torx T20, Driver

# Installation Instructions

## APPLIANCE DIMENSIONS

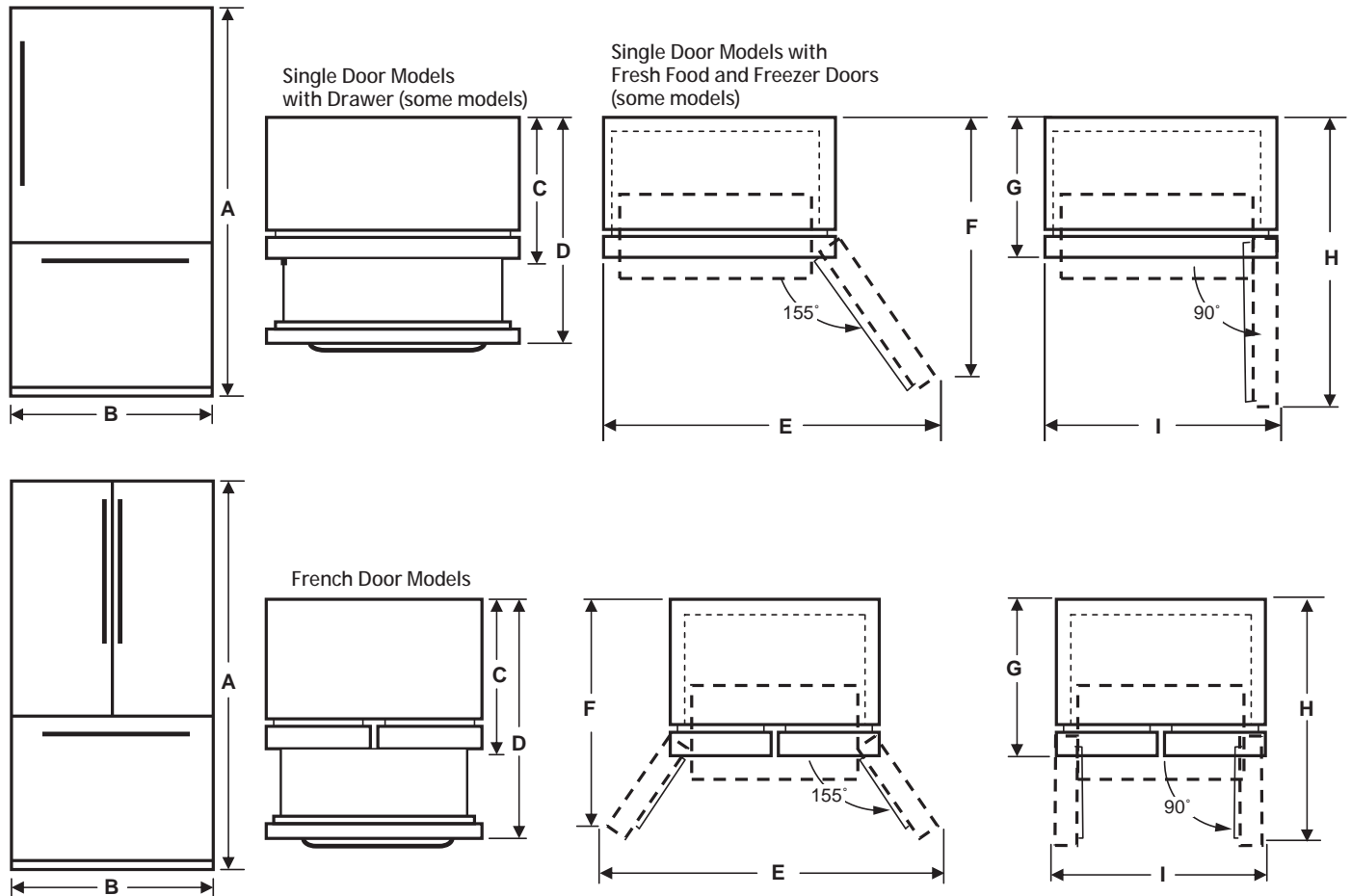

ITEM	21 cuft models with single door	21 cuft models with french doors	25 cuft models with single door	24/25 cuft models with french doors
A*	69-7/8"	69-7/8"	69-7/8"	69-7/8"
B	30"	30"	33"	33"
C**	36-1/8"	36-3/8"	37-3/8"	37-1/8"
D**	-	54"	54-3/4"	54-3/4"
E	55"	54-7/8"	60-1/2"	60-1/2"
F	45-5/8"	37"	48"	38-3/4"
G	33-7/8"	34-3/8"	34-7/8"	35-3/8"
H	61"	45-7/8"	65"	48-3/8"
I**	33-1/2"	37-5/8"	36"	40-1/2"

**NOTE:**

\* The height of the refrigerator to the top of the door.

\*\* Includes the handle.

### MEASURE THE CABINET OPENING ACCORDING TO THE WIDTH OF THE REFRIGERATOR

Measure width of cabinet opening where refrigerator will be placed, B.

Be sure to account for any countertop overhang, baseboard thickness and any clearance desired. Width, B, should not be less than 30"-33" (depending on model). The refrigerator will be placed approximately in the middle of this opening.

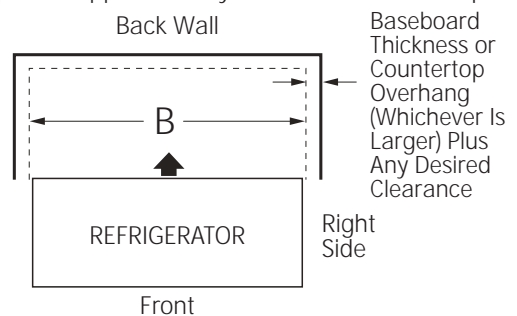

# Installation Instructions

## INSTALLING THE REFRIGERATOR

### REFRIGERATOR LOCATION

- Do not install the refrigerator where the temperature will go below 60°F (16°C) because it will not run often enough to maintain proper temperatures.
- Do not install the refrigerator where the temperature will go above 100°F (37°C) because it will not perform properly.
- Do not install the refrigerator in a location exposed to water (rain, etc.) or direct sunlight.
- Install it on a floor strong enough to support it fully loaded.

### CLEARANCES

Allow the following clearances for ease of installation, proper air circulation and plumbing and electrical connections.

Sides	1/8" (3 mm)
Top	1" (25 mm) Cabinet/Hinge Cover
Back	2" (50 mm)

### IMPORTANT NOTES

This refrigerator without the handles ranges from 34" to 35-1/4" depending on your model (see dimension G on the previous page). Doors and passageways leading to the installation location must be at least 36" in order to leave the doors attached to the refrigerator while transporting it into the installation location. If passageways are less than 36", the refrigerator doors can easily be scratched and damaged. The doors can be removed to allow the refrigerator to be safely moved indoors.

- If you need to remove the door and you have the french door model, see *Removing the French Doors* on page 20.
- If you need to remove the door and you have the single fresh food door model, see *Reversing the Door* on page 26.
- To remove the freezer door and you have the model with a freezer drawer see *Removing Freezer Drawer* on page 24.
- If you have the model with the hinged freezer door see *Reversing the Door* on page 26.
- If it is **NOT** necessary to remove doors, skip to Step 6. Leave tape and all packaging on doors until the refrigerator is in the final location. Once in place, install door handles (see Steps 1 and 2).
- **SKID REMOVAL:** Tilt refrigerator to each side to remove skid.
- **NOTE:** Use a padded hand truck to move this refrigerator. Place the refrigerator on the hand truck with a side against the truck. We strongly recommend that **TWO PEOPLE** move and complete this installation.

### 1 ATTACH FRESH FOOD HANDLE(S)

Attach the handle to the mounting fasteners by aligning the slots on the handle with the mounting fasteners. Slide the handle down until you hear a "click".

**NOTE:** For French Door models, follow the same procedure for both doors.

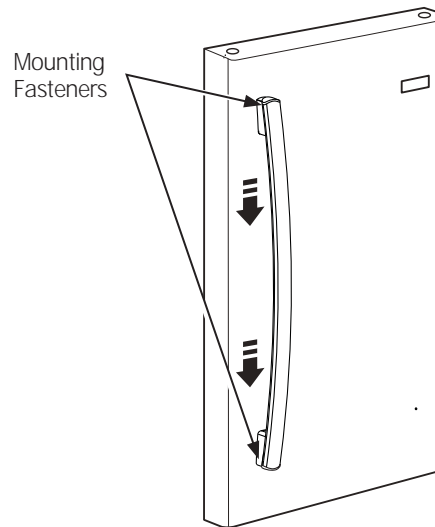

### 2 ATTACH FREEZER HANDLE

Attach the handle to the mounting fasteners by aligning the slots on the handle with the mounting fasteners. Slide the handle to the right until you hear a "click".

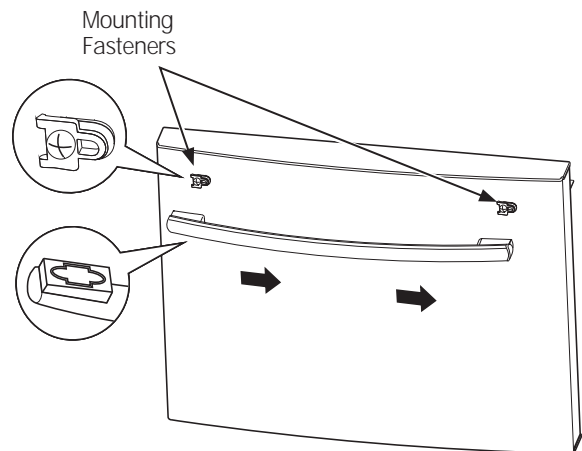

# Installation Instructions

## REMOVING FRENCH DOORS (on some models)

### IMPORTANT NOTES

When removing french doors:

- Read the instructions all the way through before starting.
- Handles are included inside the refrigerator.
- Place the screws by their related parts to avoid using them in the wrong places.
- Provide a non-scratching work surface for the doors.

#### **CAUTION**

Lifting Hazard. Single person lift can cause injury. Use assistance when handling, moving or lifting the refrigerator doors.

**NOTE:** When moving door, to prevent damage to door and electronics carefully place the door in a proper location.

#### **WARNING**

To eliminate the risk of electric shock or injury during installation, you must first unplug the refrigerator before proceeding. Failure to follow these instructions can result in electrical shock.

Tape the doors shut with adhesive tape.

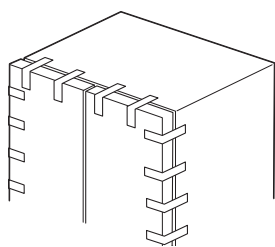

### 1 REMOVING RIGHT DOOR

- A. Remove the hinge cover on top of the right fresh food door by removing the screw using a Phillips screwdriver.

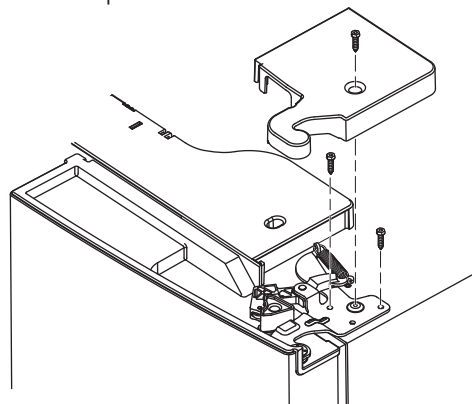

- B. Using a 5/16" socket ratchet/driver, remove the bolts securing the top hinge to the cabinet. Lift the hinge support straight up to free the hinge pin from the socket in the top of the door.

- C. Remove the tape from the right door and tilt the door away from the cabinet. Lift the door off the center hinge pin.

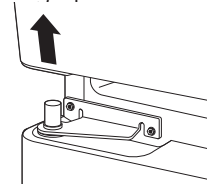

- D. Set the door on a non-scratching surface with the inside up.

### 2 REMOVING LEFT DOOR

- A. For Ice and Water Models Only: Unplug the water line from the back of the refrigerator and remove all tape that fixes the water line to the refrigerator.

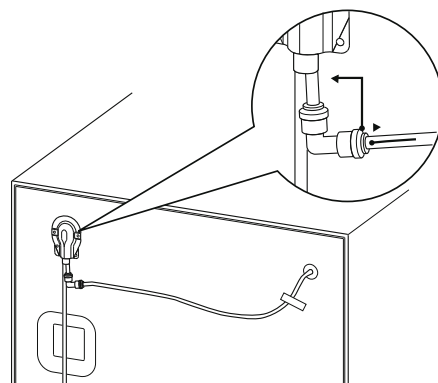

# Installation Instructions

- B. Remove the hinge cover on top of the left fresh food door by removing the screw using a Phillips screwdriver.



- C. Unplug the 3 wire connectors and move the wires until you can see the screws holding the hinge.

**For Ice and Water Models Only:** Pull the water line very carefully.

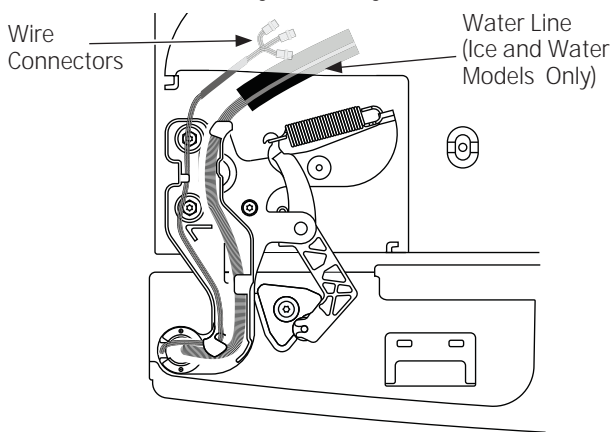

- D. Using a 5/16" socket/ratchet driver, remove the bolts securing the top hinge to the cabinet.

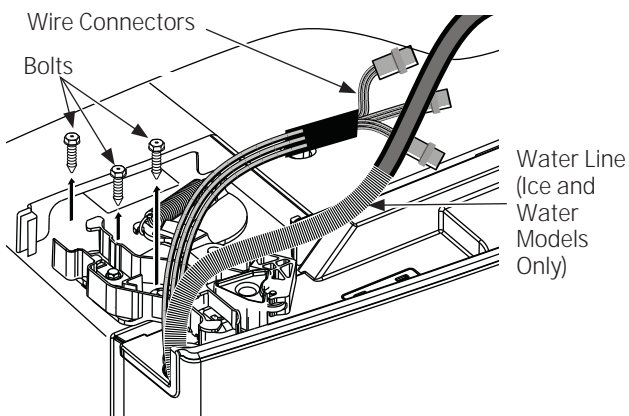

**For NON Ice and Water Models Only:** Lift the hinge straight up to free the hinge pin from the socket in the top of the door and pass the wire through the slot in the hinge. **For Ice and Water Models Only:** Do not remove hinge from the door.

- E. Remove the tape from the door, open the door 90 degrees and tilt the door away from the cabinet. Lift the door off the center hinge pin.

- F. Set the door on a non-scratching surface with the inside up.

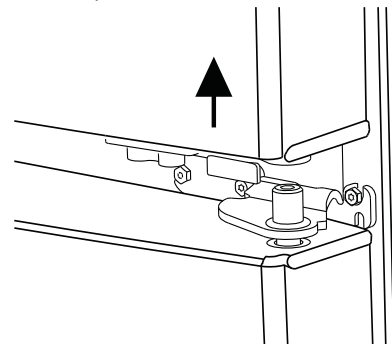

## 3 REMOVING CENTER HINGES AND BRACKETS

- A. Using a 1/4" Allen wrench, remove the 2 hinge pins from the hinge brackets.

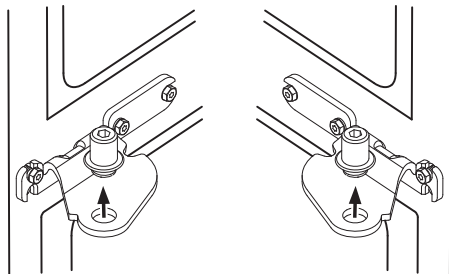

- B. Using a 5/16" socket/ratchet driver, remove the bolts securing the center hinge brackets to the cabinet.

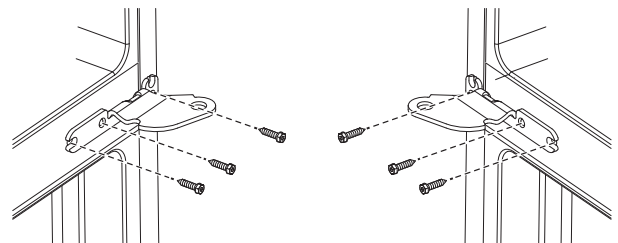

# Installation Instructions

## REINSTALLING THE FRENCH DOORS (on some models)

### IMPORTANT NOTES

When replacing the french doors:

- Read the instructions all the way through before starting.

#### ⚠ CAUTION

Lifting Hazard. Single person lift can cause injury. Use assistance when handling, moving or lifting the refrigerator doors.

**NOTE:** When moving door, to prevent damage to door and electronics carefully place the door in a proper location.

#### ⚠ WARNING

To eliminate the risk of electric shock or injury during installation, you must first unplug the refrigerator before proceeding. Failure to follow these instructions can result in electrical shock.

### 1 REINSTALLING CENTER HINGE BRACKETS AND HINGES

- A. Using a 5/16" socket/ratchet driver, reinstall the bolts and center hinge brackets to the cabinet.

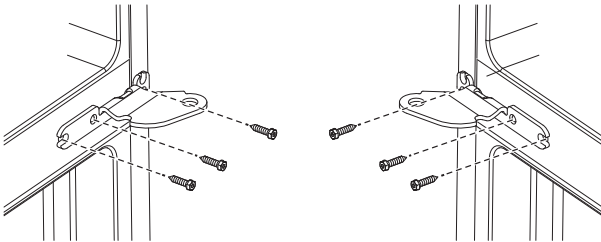

- B. Using a 1/4" Allen wrench, reinstall the 2 hinge pins into the hinge brackets.

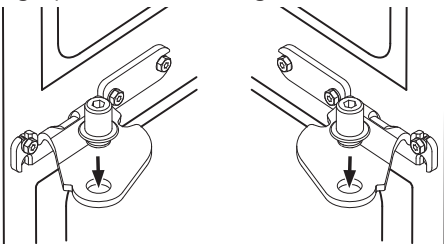

### 2 REHANGING THE RIGHT DOOR

- A. Lower the refrigerator door onto the right hinge pin.

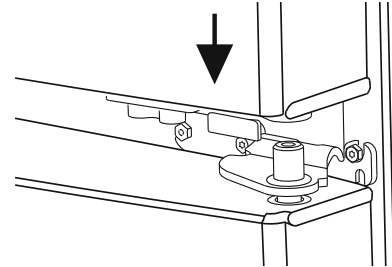

- B. Make sure the door is aligned with the cabinet. Attach the hinge to the top of the cabinet loosely with bolts removed earlier.
- C. Make sure the gasket on the door is flush against the cabinet and is not folded. Tighten the bolts to 60 lb/in.

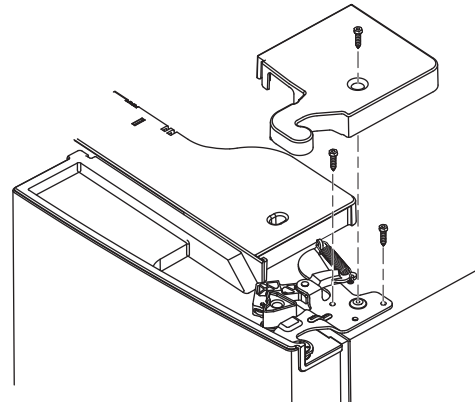

- D. Replace the right hinge cover on top of the refrigerator using a Phillips screwdriver.

### 3 REHANGING THE LEFT DOOR

- A. For **NON Ice and Water Models Only**: Pass the wire through the slot in the hinge. Place the hinge pin into the top of the door.
- B. Lower the refrigerator door onto the left hinge pin.

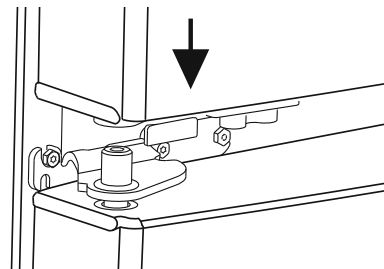

# Installation Instructions

C. Make sure the door is aligned with the cabinet. Attach the hinge to the top of the cabinet loosely with bolts removed earlier.

D. Make sure the gasket on the door is flush against the cabinet and is not folded. Tighten the bolts to 60 lb/in.

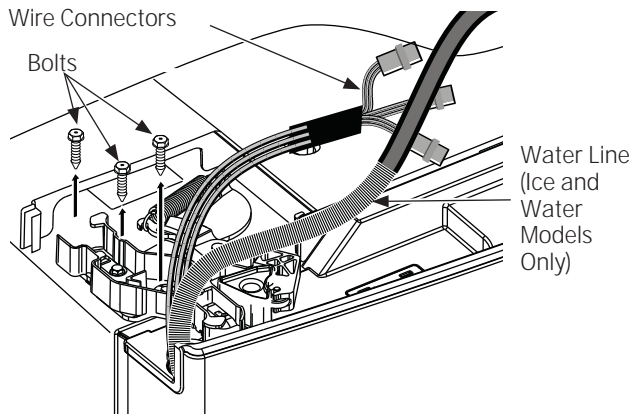

E. Plug the wire connectors together and route the wire inside the plastic port.

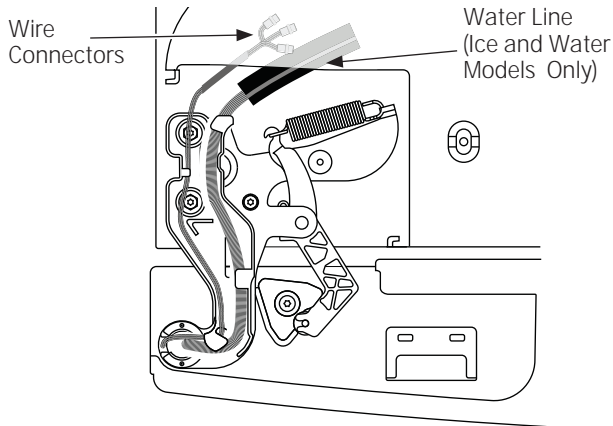

F. For Ice and Water Models Only: Put the water line into the hole and pass through the plastic port to the back of the refrigerator. Plug the water line back into the fixture on back of the refrigerator. Tape water line to the refrigerator.

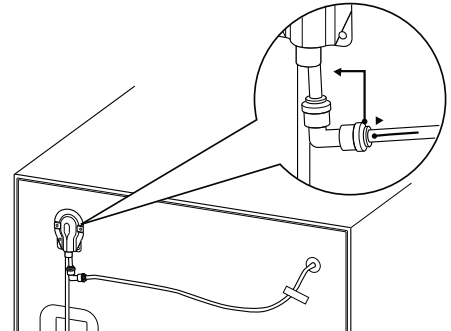

G. Replace the left hinge cover on top of the refrigerator using a Phillips screwdriver.

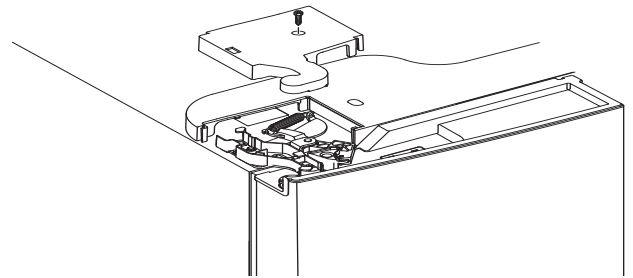

# Installation Instructions

## REMOVING FREEZER DRAWER (on some models)

### IMPORTANT NOTES

When removing freezer drawer:

- Read the instructions all the way through before starting.
- Provide a non-scratching work surface for the doors.

### 1 REMOVE THE BASKETS

- A. Open the freezer drawer until it stops.
- B. Pull the top basket out until it stops. Lift the basket up on the front and out to remove.

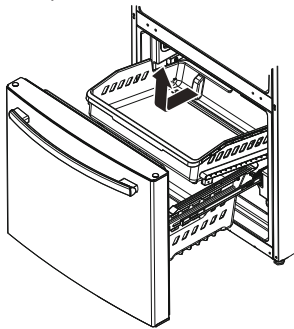

- C. The lower basket rests on a frame inside the freezer drawer. Lift the front of the basket and pull it forward. Release the pins from the slots on the frame to remove the basket.

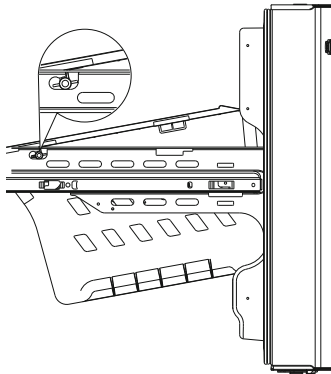

### 2 REMOVE THE DRAWER FRONT

- A. Remove the screw on each side of the railing.

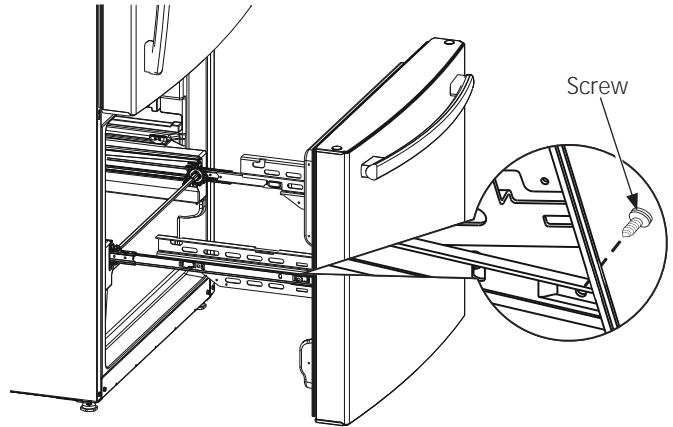

- B. Lift up on both sides of the freezer drawer handle to separate the drawer railings from the rail assemblies.

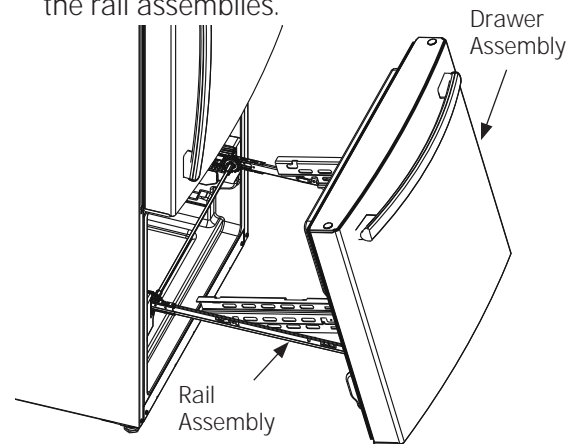

- C. Set the drawer front on a non-scratching surface.
- D. Push the rail assemblies back into locking position.



# Installation Instructions

## 3 REINSTALL FREEZER DRAWER FRONT

- A. Pull the rail assemblies to the maximum extension.
- B. Locate the slots on the inside of each slide.

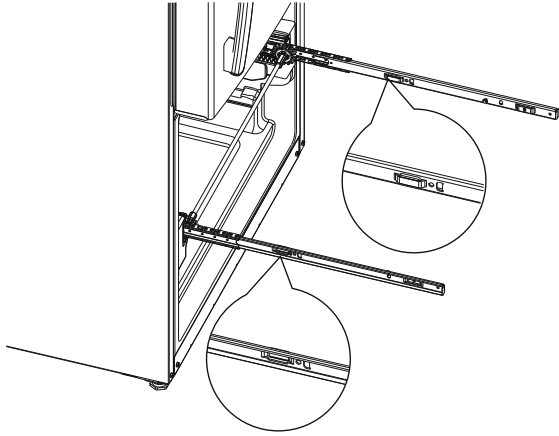

- C. Insert the hooks on the ends of the drawer assembly extensions into the slots near the back of the slides.

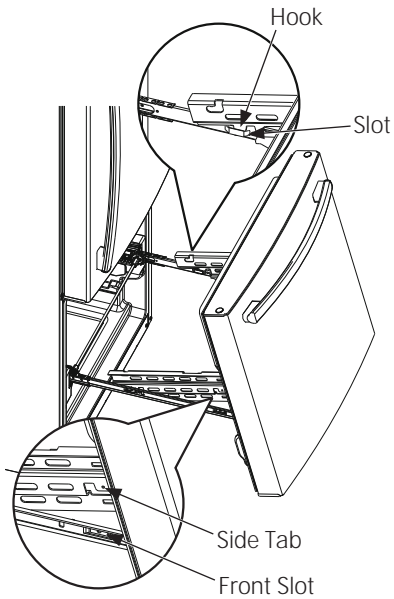

- D. Lower the front end of the freezer drawer assembly so the side tabs fit into the front slots on the rail assemblies.

- E. Replace the safety screws in both sides of the slide assemblies.

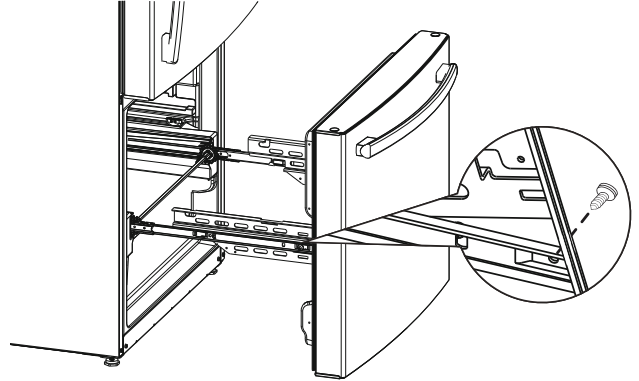

- F. Replace lower and upper baskets (see *About freezer drawer*, page 12).

# Installation Instructions

## REVERSING THE DOOR (on some models)

### IMPORTANT NOTES

When reversing doors:

- Read the instructions all the way through before starting.
- Logo badge, handles, plugs and right hinge cover are included inside the refrigerator (some models).
- Place the screws by their related parts to avoid using them in the wrong places.
- Provide a non-scratching work surface for the doors.

### ⚠ CAUTION

Lifting Hazard. Single person lift can cause injury. Use assistance when handling, moving or lifting the refrigerator doors.

**NOTE:** When removing door, to prevent damage to door and electronics carefully place the door in a proper location.

**NOTE:** The lower door hinge pin and hinge are keyed and must be matched correctly for the door to self close properly. Please follow directions carefully.

Freezer door is heavy. Use both hands to secure the door before lifting.

### ⚠ WARNING

To eliminate the risk of electric shock or injury during installation, you must first unplug the refrigerator before proceeding. Failure to follow these instructions can result in electrical shock.

### 1 REMOVE THE REFRIGERATOR DOORS

- A. Tape the door shut with masking tape.

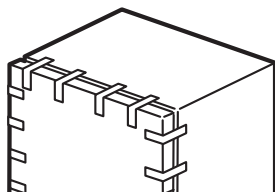

- B. Remove right and left hinge covers on top of the refrigerator using a Phillips screwdriver.

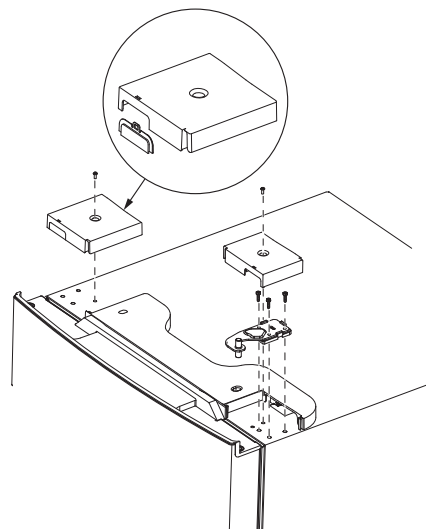

- C. Using a 5/16" socket/ratchet driver, remove the bolts securing the top hinge to the cabinet. Lift the hinge straight up to remove.

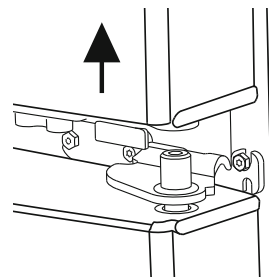

- D. Remove the tape and tilt the fresh food door away from the cabinet. Lift the door off of the center hinge pin.
- E. Set the fresh food door on a non-scratching surface with the inside up.

### For Models With a Freezer DRAWER:

- F. Using a 1/4" Allen wrench, remove the hinge pin from the hinge bracket. The hinge pin will be used again on the opposite side.
- G. Using a 5/16" socket/ratchet driver, remove the bolts securing the center hinge to the cabinet.

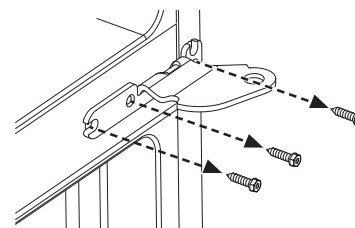
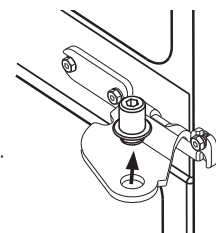

# Installation Instructions

- H. Remove the button plugs on the left side of the cabinet across from where the hinge bracket was located and install in the holes where the bracket was removed.

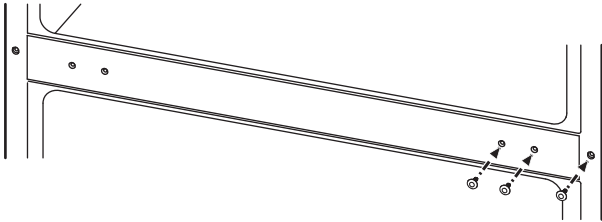

- I. Flip the center hinge bracket and install on the left side of the cabinet where the button plugs were removed.

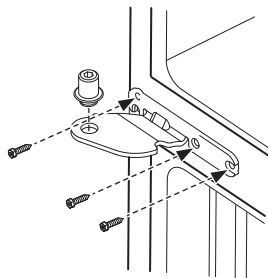

- J. Using a 1/4" Allen wrench, install the hinge pin into the center hinge bracket.

**For Models With a Freezer DOOR:**

- F. Tape the freezer door shut with adhesive tape.

- G. Using a 1/4" Allen wrench, remove the hinge pin from the hinge bracket. The hinge pin will be used again on the opposite side.

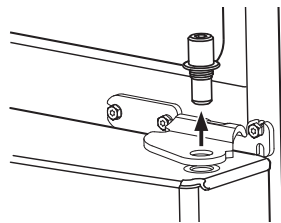

- H. Remove the tape and tilt the door away from the cabinet. Lift the door off of the bottom hinge pin.

- I. Using a thing-blade screwdriver remove the button plug from the top left side of the door and install it on the opposite side.

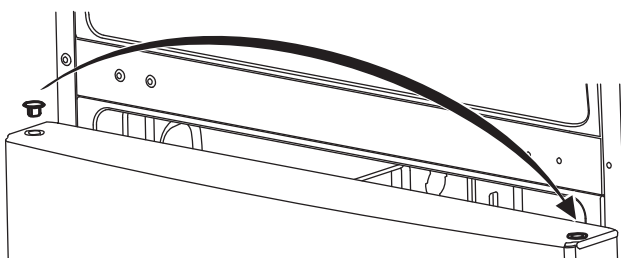

- J. Set the door on a non-scratching surface with the inside up.

- K. Using a 5/16" socket/ratchet driver, remove the bolts securing the center hinge to the cabinet.

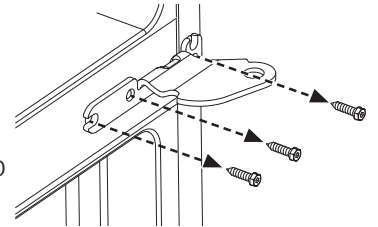

- L. Locate the button plugs in the kit and install them in the opposite side of center hinge.

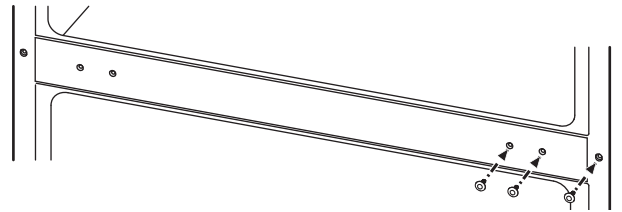

- M. Flip the center hinge bracket. Using a 5/16" socket/ratchet driver, install the center hinge bolt on the left side of the cabinet and torque to 60 in-lb.

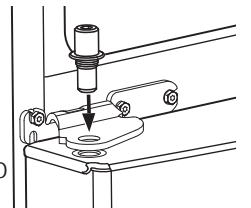

- N. Using a 1/4" Allen wrench, install the hinge pin into the center hinge bracket. Do not let the pin go past the bottom of the bracket.

- O. Using a 5/16" socket/ ratchet driver, remove the screws from the bottom hinge bracket. These will be reinstalled on the other side. Pull up on the hinge pin to remove.

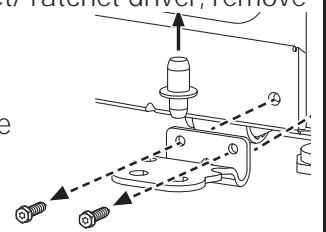

- P. Using a Torx T-20 screwdriver, remove the screw from the cabinet and install it on the other side.

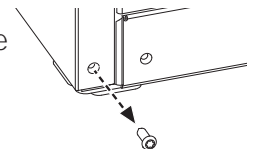

- Q. Using 5/16" socket/ ratchet driver, install the bottom hinge bracket and torque the screws to 60 in-lb. Remount the hinge and pin in the opposite hole on the cabinet.

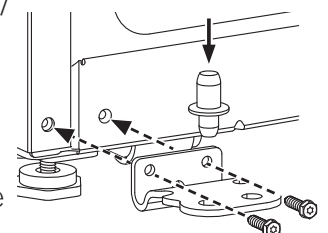

# Installation Instructions

## REVERSING THE DOOR (Cont.)

### 2 REINSTALL FREEZER DOOR.

- Using a Torx T-20 screwdriver, remove the bolts securing the door stop on the bottom right of the door.
- Using a Trox T-20 screwdriver, remove the plastic force closure on the bottom right of the door.
- Flip the plastic force closure and mount it to the bottom left of the door.
- Install the door stop to the bottom left of the door.

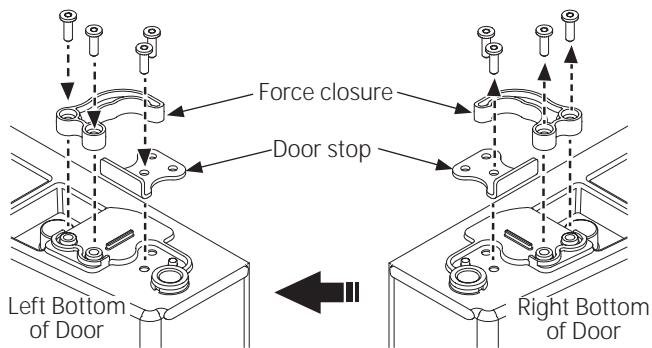

- Lower the freezer door and make sure to insert the hinge pin in the bottom hole of the door.

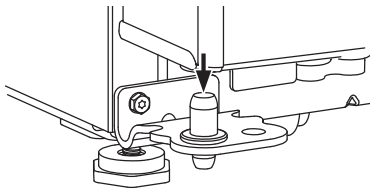

- Straighten the door and line it up with the center hinge bracket. Using a 1/4" Allen wrench, turn the hinge pin until it extends through the hinge bracket and into the door.

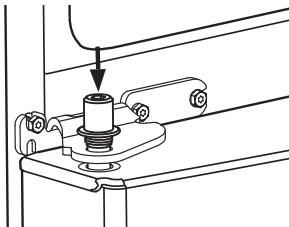

### 3 REINSTALL FRESH FOOD DOOR.

- Using a Torx T-20 screwdriver, remove the bolts securing the door stop on the bottom right of the door.

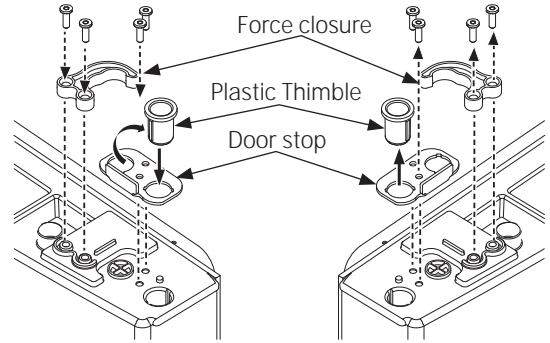

- Transfer the plastic thimble to the opposite hole. Install the door stop with the plastic thimble on the opposite side.
- Using a Trox T-20 screwdriver, remove the plastic force closure on the bottom right of the door.
- Flip the plastic force closure and mount it to the bottom left of the door.
- Install the door stop to the bottom left of the door.
- Lower the fresh food door and make sure to insert the hinge pin in the bottom hole of the door.

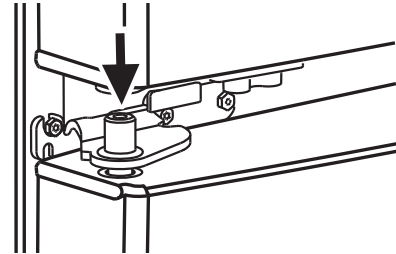

- Remove the hinge base from the hinge. Flip the hinge over and remount to hinge base.

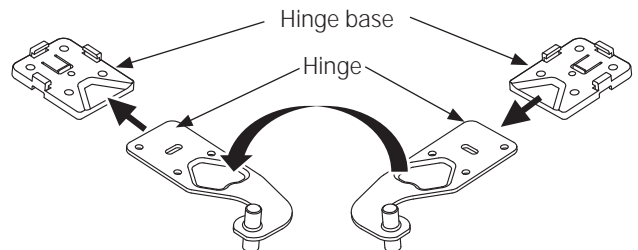

# Installation Instructions

- H. Insert the top hinge pin inside the hole in the top left of the fresh food door. Make sure the door is aligned with the cabinet. Attach the hinge to the top of the cabinet loosely with the bolts that were removed previously.

Make sure the gasket on the door is flush against the cabinet and not folded. Support the door on the handle side and make sure the door is straight and the gap between the doors is even across the front. While holding the door in place, tighten the screws to 60 in-lb.

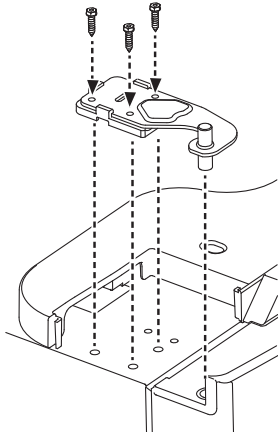

## For Models with a Freezer DRAWER:

- I. Remove the front insert from the left hinge cover. Install the left hinge cover using a Phillips screwdriver and the screw removed earlier.

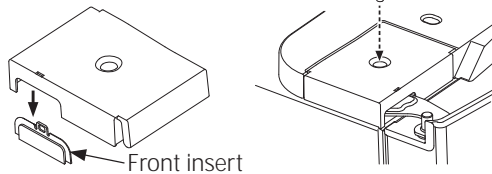

- J. Install the front insert into the right hinge cover. Install the right hinge cover using a Phillips screwdriver and the screws removed earlier.

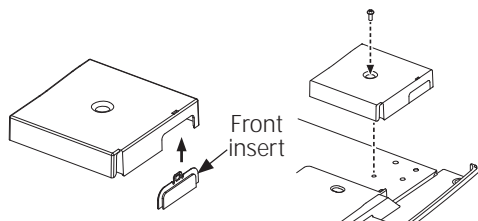

## For Models with a Freezer DOOR:

- I. Locate the left hinge cover that comes with the kit. Using a Phillips screwdriver, install the cover with the screws provided.

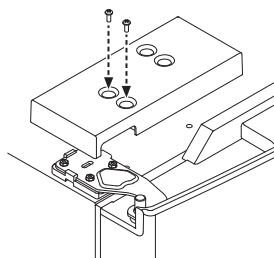

- J. Locate the insert for the right hinge cover that comes with the kit and install.

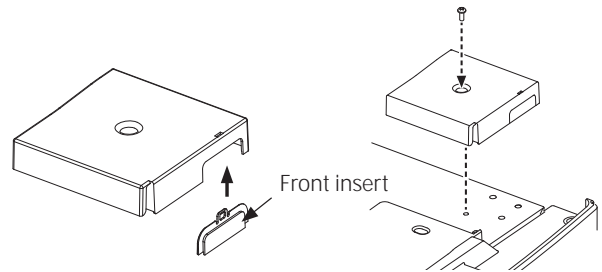

- K. Using a Phillips screwdriver, install the right hinge cover with screws provided.

## 4 TRANSFER HANDLE MOUNTING FASTENERS

- A. Remove the plug from the lower right hole.  
B. Using a Phillips screwdriver remove the screws holding the mounting brackets from the left side and install them on the right side.

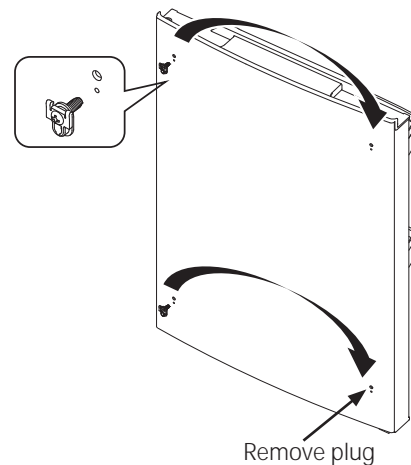

## 5 INSTALLING LOGO BADGE

- A. Locate the new logo badge from the kit. Remove the adhesive backing paper and align the pins on the back of the badge with the holes in the door. Apply pressure to the badge to ensure it sticks to the door.  
B. Locate the button plug from the kit and install it in the opposite side of handle.

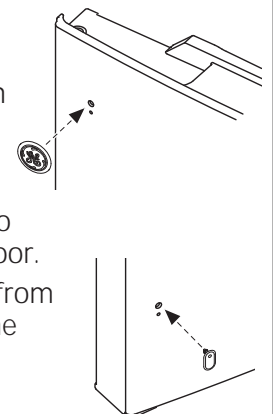

# Installation Instructions

## INSTALLING THE REFRIGERATOR (cont.)

### 6 CONNECTING THE REFRIGERATOR TO THE HOUSE WATER LINE

(Icemaker models only)

A cold water supply is required for automatic ice maker operation. If there is not a cold water supply, you will need to provide one. See Installing the Water Line section.

#### NOTES:

- Before making the connection to the refrigerator, be sure the refrigerator power cord is not plugged into the wall outlet.
- If your refrigerator does not have a water filter, we recommend installing one if your water supply has sand or particles that could clog the screen of the refrigerator's water valve. Install it in the water line near the refrigerator. If using GE SmartConnect™ Refrigerator Tubing Kit, you will need an additional tube (WX08X10002) to connect the filter. Do not cut plastic tube to install filter.
- Before connecting the water line to the house, purge the house line for at least 2 minutes.

**A. If you are using copper tubing,** place a compression nut and ferrule (sleeve) onto the end of the tubing coming from the house cold water supply.

**If you are using the GE SmartConnect™ tubing,** the nuts are already assembled to the tubing.

**B. If you are using copper tubing,** insert the end of the tubing into the refrigerator connection, at the back of the refrigerator, as far as possible. While holding the tubing, tighten the fitting.

**If you are using GE SmartConnect™ tubing,** insert the molded end of the tubing into the refrigerator connection, at the back of the refrigerator, and tighten the compression nut until it is hand tight. Then tighten one additional turn with a wrench. Over tightening may cause leaks.

**C. Fasten the tubing into the clamp** provided to hold it in position. You may need to pry open the clamp.

One of the illustrations below will look like the connection on your refrigerator.

#### Icemaker-Ready Models

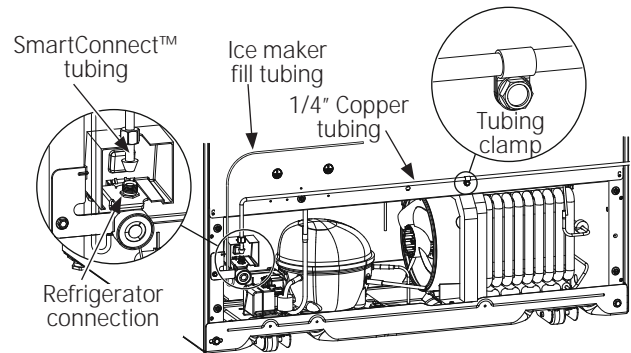

#### Icemaker-Installed Models

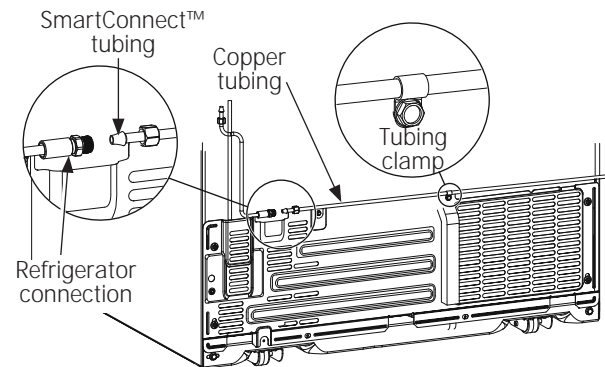

# Installation Instructions

## 7 TURN ON THE WATER SUPPLY (Icemaker models)

Turn the water on at the shutoff valve (house water supply) and check for any leaks.

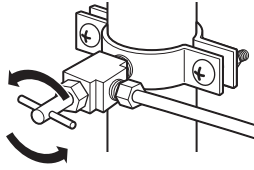

## 8 PLUG IN THE REFRIGERATOR

On models with an icemaker, before plugging in the refrigerator, make sure the icemaker power switch is set to the 0 (off) position.

See the grounding information attached to the power cord.

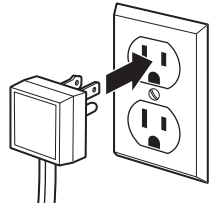

## 9 PUT THE REFRIGERATOR IN PLACE

Move the refrigerator to its final location.

## 10 LEVEL THE REFRIGERATOR

**Adjustable legs** at the front corners of the refrigerator should be set so the refrigerator is firmly positioned on the floor, and the front is raised just enough that the door closes easily when opened about halfway.

**To adjust the leveling legs**, turn the legs **clockwise to raise** the refrigerator, **counterclockwise to lower** it.

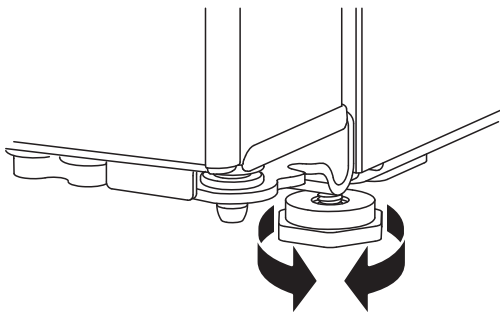

## 11 LEVEL THE REFRIGERATOR DOORS (on some models)

Remember a level refrigerator is necessary for getting the doors perfectly even. If you need help, review the previous section on leveling the refrigerator.

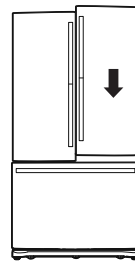

When the left door is lower than the right door.

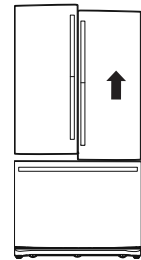

When the left door is higher than the right door.

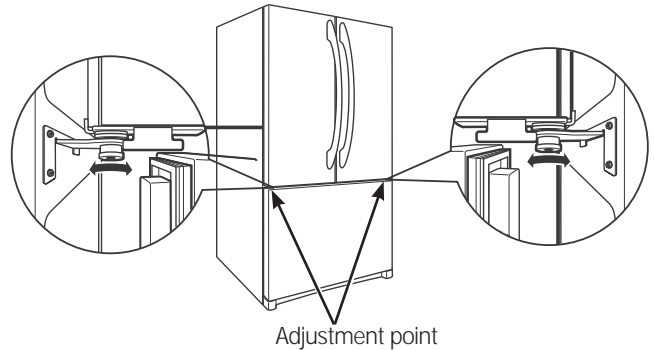

If the doors remain uneven, turn the adjustable pin to raise the lowest door using a 1/4" allen wrench to turn the pin.

# Installation Instructions

Refrigerator suggested assembly.  
Shelves shown in the location for best energy efficiency.

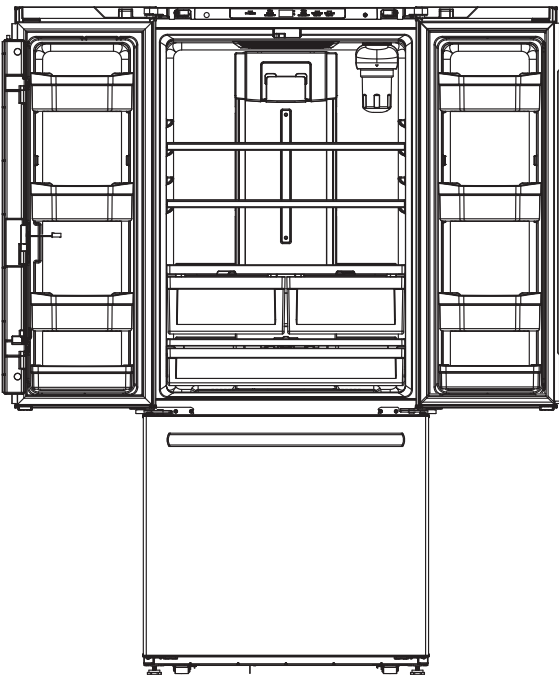

GNE21 Models  
French Door with Freezer Drawer

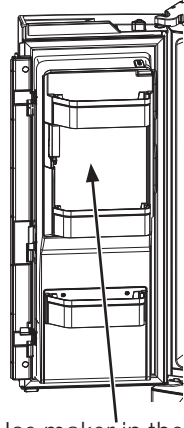

Ice maker in the door is available for all 24 french door models.

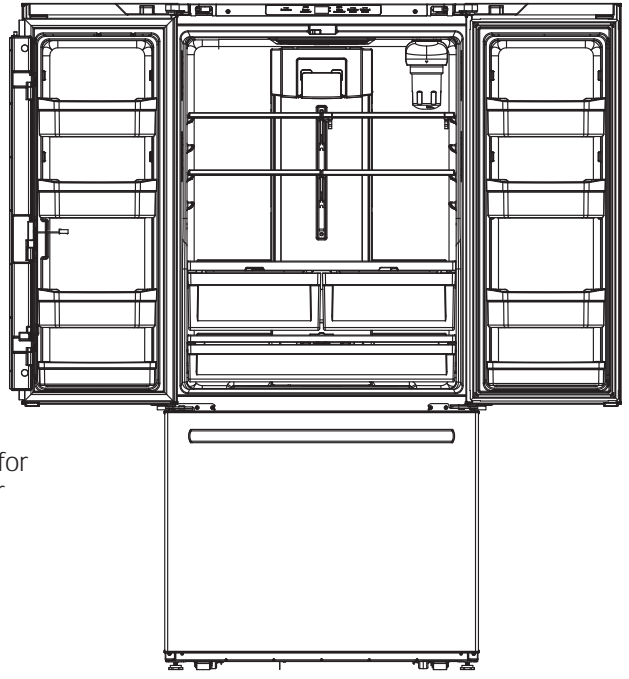

GFE24, PFE24, CFE24, GNE25, PNE25,  
CNE25 Models  
French Door with Freezer Drawer

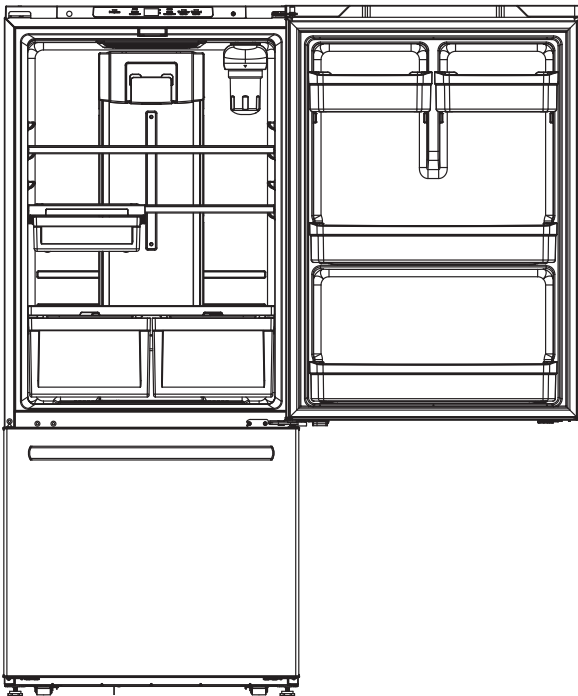

GDE21, GDE25 Models  
Single Door with Freezer Drawer

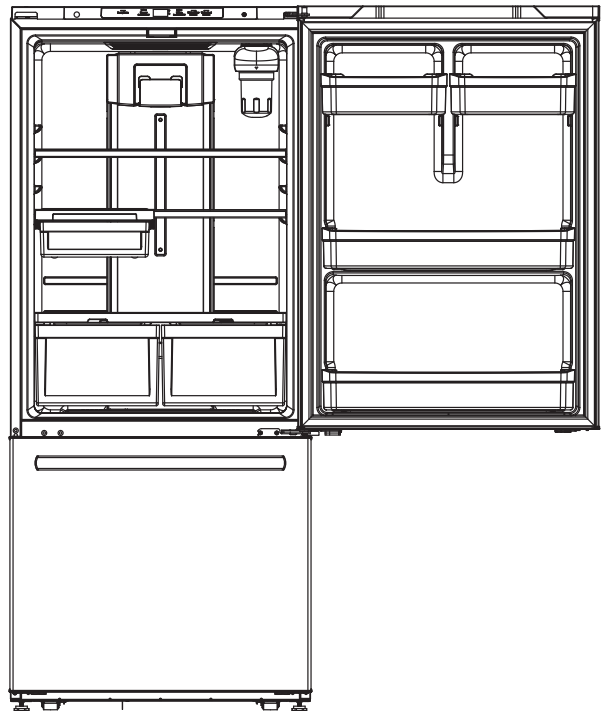

GBE21, ABE21 Models  
Single Door with Freezer Door



# Installation Instructions

## INSTALLING THE WATER LINE

### BEFORE YOU BEGIN

Recommended copper water supply kits are WX8X2, WX8X3 or WX8X4, depending on the amount of tubing you need. Approved plastic water supply lines are GE SmartConnect™ Refrigerator Tubing (WX08X10006, WX08X10015 and WX08X10025).

When connecting your refrigerator to a GE Reverse Osmosis Water System, the only approved installation is with a GE Appliances RVKit. For other reverse osmosis water systems, follow the manufacturer's recommendations.

If the water supply to the refrigerator is from a Reverse Osmosis Water Filtration System (RO) AND the refrigerator also has a water filter, use the refrigerator's filter bypass plug. Using the refrigerator's water filtration cartridge in conjunction with an RO water filter can result in hollow ice cubes. Some models do not come equipped with the filter bypass plug. To obtain a free bypass plug, call 800-GEARES. In Canada call 800.561.3344.

This water line installation is not warranted by the refrigerator or ice maker manufacturer. Follow these instructions carefully to minimize the risk of expensive water damage.

Water hammer (water banging in the pipes) in house plumbing can cause damage to refrigerator parts and lead to water leakage or flooding. Call a qualified plumber to correct water hammer before installing the water supply line to the refrigerator.

To prevent burns and product damage, do not hook up the water line to the hot water line.

Do not install the ice maker tubing in areas where temperatures fall below freezing.

When using any electrical device (such as a power drill) during installation, be sure the device is double insulated or grounded in a manner to prevent the hazard of electric shock, or is battery powered.

All installations must be in accordance with local plumbing code requirements.

### WHAT YOU WILL NEED

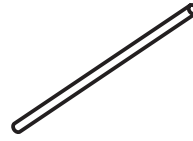

- Copper or GE SmartConnect™ Refrigerator Tubing kit, 1/4" outer diameter to connect the refrigerator to the water supply. If using copper, be sure both ends of the tubing are cut square.

To determine how much tubing you need: measure the distance from the water valve on the back of the refrigerator to the water supply pipe. Be sure there is sufficient extra tubing to allow the refrigerator to move out from the wall after installation.

GE SmartConnect™ Refrigerator Tubing Kits are available in the following lengths:

6' (1.8 m)	– WX08X10006
15' (4.6 m)	– WX08X10015
25' (7.6 m)	– WX08X10025

# Installation Instructions

## INSTALLING THE WATER LINE (cont.)

### WHAT YOU WILL NEED (CONT.)

NOTE: The only GE Appliances approved plastic tubing is that supplied in GE SmartConnect™ Refrigerator Tubing kits. Do not use any other plastic water supply line because the line is under pressure at all times. Certain types of plastic will crack or rupture with age and cause water damage to your home.

- A GE Appliances water supply kit (containing tubing, shutoff valve and fittings listed below) is available at extra cost from your dealer or from Parts and Accessories, 800.626.2002 (in Canada 1.800.661.1616).
- A cold water supply. The water pressure must be between 20 and 120 p.s.i. (1.4–8.1 bar).

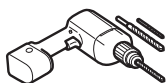

- Power drill.
- 1/2" or adjustable wrench.
- Straight and Phillips blade screwdriver.

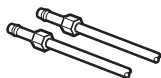

- Two 1/4" outer diameter compression nuts and 2 ferrules (sleeves)—to connect the copper tubing to the shutoff valve and the refrigerator water valve.

OR

- If you are using a GE SmartConnect™ Refrigerator Tubing kit, the necessary fittings are preassembled to the tubing.

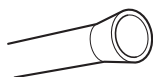

- If your existing copper water line has a flared fitting at the end, you will need an adapter (available at plumbing supply stores) to connect the water line to the refrigerator OR you can cut off the flared fitting with a tube cutter and then use a compression fitting. Do not cut formed end from GE SmartConnect™ Refrigerator tubing.

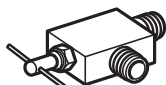

- Shutoff valve to connect to the cold water line. The shutoff valve should have a water inlet with a minimum inside diameter of 5/32" at the point of connection to the COLD WATER LINE. Saddle-type shutoff valves are included in many water supply kits. Before purchasing, make sure a saddle-type valve complies with your local plumbing codes.

Install the shutoff valve on the nearest frequently used drinking water line.

### 1 SHUT OFF THE MAIN WATER SUPPLY

Turn on the nearest faucet long enough to clear the line of water.

### 2 CHOOSE THE VALVE LOCATION

Choose a location for the valve that is easily accessible. It is best to connect into the side of a vertical water pipe. When it is necessary to connect into a horizontal water pipe, make the connection to the top or side, rather than at the bottom, to avoid drawing off any sediment from the water pipe.

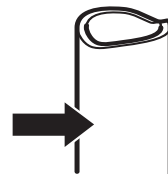

### 3 DRILL THE HOLE FOR THE VALVE

Drill a 1/4" hole in the water pipe (even if using a self-piercing valve), using a sharp bit. Remove any burrs resulting from drilling the hole in the pipe.

Take care not to allow water to drain into the drill.

Failure to drill a 1/4" hole may result in reduced ice production or smaller cubes.

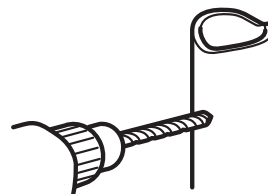

# Installation Instructions

## 4 FASTEN THE SHUTOFF VALVE

Fasten the shutoff valve to the cold water pipe with the pipe clamp.

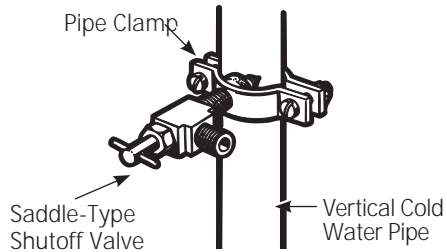

**NOTE:** Commonwealth of Massachusetts Plumbing Codes 248CMR shall be adhered to. Saddle valves are illegal and use is not permitted in Massachusetts. Consult with your licensed plumber.

## 5 TIGHTEN THE PIPE CLAMP

Tighten the clamp screws until the sealing washer begins to swell.

**NOTE:** Do not over tighten or you may crush the tubing.

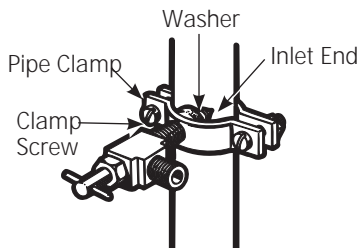

## 6 ROUTE THE TUBING

Route the tubing between the cold water line and the refrigerator.

Route the tubing through a hole drilled in the wall or floor (behind the refrigerator or adjacent base cabinet) as close to the wall as possible.

## 7 CONNECT THE TUBING TO THE VALVE

Place the compression nut and ferrule (sleeve) for copper tubing onto the end of the tubing and connect it to the shutoff valve.

Make sure the tubing is fully inserted into the valve. Tighten the compression nut securely.

For plastic tubing from a GE SmartConnect™ Refrigerator Tubing kit, insert the molded end of the tubing into the shutoff valve and tighten compression nut until it is hand tight, then tighten one additional turn with a wrench. Over tightening may cause leaks.

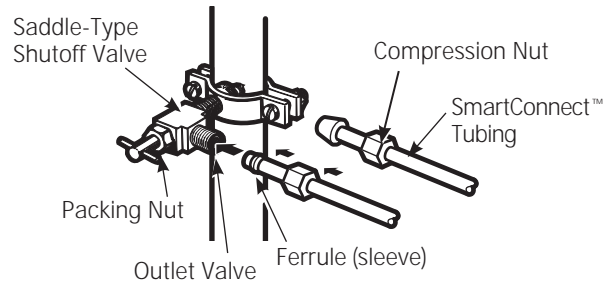

**NOTE:** Commonwealth of Massachusetts Plumbing Codes 248CMR shall be adhered to. Saddle valves are illegal and use is not permitted in Massachusetts. Consult with your licensed plumber.

## 8 FLUSH OUT THE TUBING

Turn the main water supply on and flush out the tubing until the water is clear.

Shut the water off at the water valve after about one quart (1 liter), or 2 minutes, of water has been flushed through the tubing.



To complete the installation of the refrigerator, go back to Step 11 in Installing the Refrigerator.

## Normal operating conditions.

---



Newer refrigerators sound different from older refrigerators.  
Modern refrigerators have more features and use newer technology.

**Do you hear what I hear? These conditions are normal.**

**HUMMM...  
WHOOSH...**

- The new high efficiency compressor may run faster and longer than your old refrigerator and you may hear a high-pitched hum or pulsating sound while it is operating.
- You may hear a whooshing sound when the doors close. This is due to pressure equalizing within the refrigerator.



- You may hear the fans spinning at high speeds. This happens when the refrigerator is first plugged in, when the doors are opened frequently or when a large amount of food is added to the refrigerator or freezer compartments. The fans are helping to maintain the correct temperatures.
- The fans change speeds in order to provide optimal cooling and energy savings.

**CLICKS, POPS,  
CRACKS and SNAPS**

- You may hear cracking or popping sounds when the refrigerator is first plugged in. This happens as the refrigerator cools to the correct temperature.
- Expansion and contraction of cooling coils during and after defrost can cause a cracking or popping sound.
- On models with an ice maker, after an ice making cycle, you may hear the ice cubes dropping into the ice bucket.
- On models with a dispenser, during water dispense, you may hear the water lines move at initial dispense and after dispenser button is released.

**WATER SOUNDS**



- The flow of refrigerant through the cooling coils may make a gurgling noise like boiling water.
- Water dropping on the defrost heater can cause a sizzling, popping or buzzing sound during the defrost cycle.
- A water dripping noise may occur during the defrost cycle as ice melts from the evaporator and flows into the drain pan.
- Closing the door may cause a gurgling sound due to pressure equalization.

## Before you call for service...



*Troubleshooting Tips*  
*Save time and money! Review the charts on the following pages first and you may not need to call for service.*

Problem	Possible Causes	What to Do
Water filter indicator light remains lit after replacing filter (on some models)	Water filter indicator must be reset	Press WATER FILTER pad for 3 seconds to reset the water filter.
Water filter indicator light is not lit (on some models)	This is normal. This indicator will turn on to tell you that you need to replace the filter soon.	See <i>About the Water Filter</i> for more information.
Handle is loose/handle has a gap.	Handle needs adjusting	See <i>Attach Fresh Food Handle</i> and <i>Attach Freezer Handle</i> sections for detailed instructions.
Refrigerator beeping	This is door alarm	Turn off or disable with door closed. If door open and alarm is sounding, you can only snooze the alarm.
Not cooling	The cooling system is off	See <i>About Controls</i> .
Water has poor taste/odor (on some models)	Water dispenser has not been used for a long time	Dispense water, until all water in system is replenished.
Water in glass is warm (on some models)	Normal when refrigerator is first installed	Wait 24 hours for the refrigerator to completely cool down.
	Water dispenser has not been used for a long time	Dispense water, until all water in system is replenished.
	Water system has drained	Allow several hours for replenished supply to chill.
Water dispenser does not work (on some models)	Water supply line turned off or not connected	See <i>Installing the Water Line</i> .
	Water filter clogged or filter/bypass plug not installed	Replace filter cartridge or remove filter and install bypass plug.*
	Air may be trapped in the water system	Press the dispenser arm for at least 5 minutes.
	Water in reservoir is frozen because the controls are set too cold	Set the refrigerator control to a warmer setting and wait 24 hours. If the water does not dispense after 24 hours, call for service.
Water spurting from dispenser (on some models)	Newly installed filter cartridge	Run cold water from the dispenser for 5 minutes (about 2 gallons)..

\*Some models do not come equipped with the filter bypass plug. To obtain a free bypass plug, call 800-GECARES. In Canada call 800.561.3344.

## Before you call for service...



### Troubleshooting Tips (cont)

Problem	Possible Causes	What to Do
No water or ice cube production (on some models)	Supply line or shutoff valve is clogged	Call a plumber
	Water filter is clogged	Replace filter cartridge or remove filter and install bypass plug*.
	Filter cartridge not properly installed	Remove and reinstall filter cartridge, being certain that it locks in place.
	Ice maker is turned off	Check that the ice maker is turned on. See <i>About the Automatic Ice Maker</i> .
Water is leaking from dispenser (on some models)	Air may be present in the water line system, causing water to drip after being dispensed	Dispense water for at least 5 minutes to remove air from system.
Freezer cooling, fresh food not cooling	Normal, when refrigerator first plugged in or after extended power outage	Wait 24 hours for temperature in both compartments to reach selected temperatures.
Ice dispenser opens after closing freezer drawer (on some models)	Normal	The ice dispenser door may open after closing freezer door to allow access.

\*Some models do not come equipped with the filter bypass plug. To obtain a free bypass plug, call 800-GECARES. In Canada call 800.561.3344.

# SERVICE

Before you call for service, review the detailed troubleshooting tips in the Owner's manual. If needed, service can be scheduled by visiting us online [GEAppliances.com](http://GEAppliances.com) or calling 800.ge.CARES 800.432.2737

## Truth or Myth

Truth or Myth?	Answer	Explanation
The refrigerator water filter may require replacement, even though the filter indicator has not turned red, or reads "Filter Expired."	TRUE	The water filter indicator will indicate the need to replace the water filter every six months. Water quality varies from city to city; if water flow from the dispenser slows, or ice production decreases, the water filter should be replaced, even though the filter indicator may not indicate the need for replacement.
The automatic ice maker in my refrigerator will produce ice when the refrigerator is plugged in to a power receptacle.	MYTH	The refrigerator must be connected to water, and the ice maker must be turned on. Make sure the ice maker is turned on, only after the water line is connected and water is turned on. The ice maker can be turned <b>on/off</b> from the controls and ensure the ice maker is on, as indicated on the refrigerator control panel. See <i>About the Automatic Ice Maker</i> .
After the refrigerator has been plugged in and connected to water, I will immediately have unlimited chilled water available from the water dispenser.	MYTH	The water dispenser tank located inside the refrigerator stores water for dispensing. The water in this tank requires 24 hours to chill after installation. High usage conditions will not allow time for the water to chill.
After water dispenses, a few drops of water are normal.	TRUE	A few drops of water may fall from the dispenser, after the dispenser paddle has been released. To minimize the drops, remove the glass slowly from the dispenser.
I will never see frost inside the freezer compartment.	MYTH	Frost inside the freezer typically indicates that the door is not properly sealed, or has been left open. If frost is found, clear the frost using a plastic spatula and towel, then check to ensure that no food packages or containers are preventing the freezer door from closing. Check the refrigerator control panel to ensure the door alarm is on.
When the refrigerator is installed, or after replacing the water filter, I must dispense water for five minutes.	TRUE	A newly installed refrigerator or water filter contains air in the water lines. Press the dispenser paddle and dispense cold water for at least 5 minutes to remove air from the water line, and flush the filter.
To fill the ice bucket to the maximum capacity, I should dispense 12 and 18 hours after installation.	TRUE	Dispensing 3-4 cubes 12 hours and 18 hours after installation, allows ice to disperse within the ice bucket, which in turns calls on the ice maker to produce additional ice. Normal ice production = 100 cubes in 24 hours.
I can use the water filter bypass plug to determine if the filter requires replacement.	TRUE	Decrease in flow from the water dispenser, or decreased ice production, may indicate the need to replace the water filter. Install the water filter bypass plug (provided with the refrigerator on some models*), and check flow from the dispenser. If water flow returns to normal with the bypass plug in place, replace the water filter.
The top of the refrigerator doors will always be aligned.	MYTH	Several things can affect the fresh food door alignment, including the floor the refrigerator is installed on and loading of doors. If the top of the fresh food doors are not aligned, use a 1/4" allen wrench to adjust the right/left hand door. The adjustment screw is located on the bottom right or left hand side of the door; open the freezer door to access the screw. On some models, the left hand fresh food door may be raised using spacers. Call 800-GEARES to obtain the spacers.
Refrigerator door handles can be easily tightened.	TRUE	If door handles are loose or have a gap, the handle can be adjusted using a 1/8" allen wrench, on set screws located on the ends of the handles.
There may be odor and taste problems with your ice.	TRUE	After starting the ice maker throw away 24 hours of ice production to avoid odor and taste problems.
I can make fine adjustments to the fresh food doors to align them.	TRUE	If the fresh food doors are not aligned, use a 1/4" Allen wrench to adjust the right hand door. The adjustment screw is located on the bottom of the right door. Open the freezer door to access. The left hand fresh food door may be raised using spacers. Call 800-GEARES to obtain the spacers.
Door handles should always be removed for installation.	MYTH	Check chart on reverse side of this instruction. If the doors must be removed do not remove the handles, or if the refrigerator will fit easily through the passage way opening. Adjust handles that are loose or have a gap, by adjusting 1/8" set screws on either end of handles.

## SERVICE

Before you call for service, review the detailed troubleshooting tips in the Owner's manual. If needed, service can be scheduled by visiting us online *GEAppliances.com* or calling 800.ge.CARES 800.432.2737

## Truth or Myth (cont.)

Truth or Myth?	Answer	Explanation
Door removal is always required for installation.	MYTH	Check chart on reverse side of this instruction. Doors should only be removed when necessary to prevent damage from passage way or access to final location.
Refrigerator doors that won't close after installation, can be adjusted to close properly.	TRUE	Door mechanism works best if installed at 90°. If installed at 180°, remove the door from the mid hinge, and swing the door 180° before reinstalling. See <i>Reinstalling the Refrigerator Doors</i> .
There is an adjustment to rear wheels.	MYTH	Front leveling legs are adjustable and should be used to balance the refrigerator. Leveling legs are used to make initial fresh food door adjustment.
Check for leaks after all water connections are made.	TRUE	While purging the air from the water system, check all water line connections for leaks. Check the connection to the household water supply at back of refrigerator, and door water line connect.
Any packaging residue can be cleaned off the refrigerator using any cleaner.	MYTH	Do not use wax, polish, bleach, or other products containing chlorine on Stainless Steel panels, door handles and trim. Check this instruction under "Cleaning the Outside" for full details.

\*Some models do not come equipped with the filter bypass plug. To obtain a free bypass plug, call 800-GE CARES. In Canada call 800.561.3344.



# Refrigerator Warranty. *(For customers in the United States)*



All warranty service provided by our Factory Service Centers, or an authorized Customer Care® technician. To schedule service, visit us online at [GEAppliances.com](http://GEAppliances.com), or call 800.GE.CARES (800.432.2737). Please have serial number and model number available when calling for service.

Staple your receipt here. Proof of the original purchase date is needed to obtain service under the warranty.

**Servicing your refrigerator may require the use of the onboard data port for diagnostics. This gives a GE Appliances Factory Service technician the ability to quickly diagnose any issues with your appliance and helps GE Appliances improve its products by providing GE Appliances with information on your appliance. If you do not want your appliance data to be sent to GE Appliances, please advise your technician NOT to submit the data to GE Appliances at the time of service.**

For the Period of:	GE Appliances Will Replace
<b>One Year</b> From the date of the original purchase	<b>Any part</b> of the refrigerator which fails due to a defect in materials or workmanship. During the <b>limited one-year warranty</b> , GE Appliances will also provide, <b>free of charge</b> , all labor and related service to replace the defective part.
<b>Thirty Days</b> (Water filter, if included) From the original purchase date of the refrigerator	<b>Any part</b> of the water filter cartridge which fails due to a defect in materials or workmanship. During this <b>limited thirty-day warranty</b> , GE Appliances will also provide, <b>free of charge</b> , a replacement water filter cartridge.
<b>GE PROFILE™ AND GE CAFÉ™ MODELS</b>	
<b>Five Years</b> From the date of the purchase	<b>Any part of the sealed refrigerating system</b> (the compressor, condenser, evaporator and all connecting tubing) which fails due to a defect in materials or workmanship. During this <b>limited five-year sealed refrigerating system warranty</b> , GE Appliances will also provide, <b>free of charge</b> , all labor and related service to replace the defective part in the sealed refrigerating system.

## What GE Appliances Will Not Cover:

- Service trips to your home to teach you how to use the product.
- Improper installation, delivery or maintenance.
- Failure of the product if it is abused, misused, or used for other than the intended purpose or used commercially.
- Loss of food due to spoilage.
- Replacement of house fuses or resetting of circuit breakers.
- Damage caused after delivery.
- Replacement of the water filter cartridge, if included, due to water pressure that is outside the specified operating range or due to excessive sediment in the water supply.
- Replacement of the light bulbs, if included, or water filter cartridge, if included, other than as noted above.
- Damage to the product caused by accident, fire, floods or acts of God.
- Incidental or consequential damage caused by possible defects with this appliance.
- Product not accessible to provide required service.
- Damage caused by a non-GE Appliances Brand water filter.

**EXCLUSION OF IMPLIED WARRANTIES—Your sole and exclusive remedy is product repair as provided in this Limited Warranty. Any implied warranties, including the implied warranties of merchantability or fitness for a particular purpose, are limited to one year or the shortest period allowed by law.**

This warranty is extended to the original purchaser and any succeeding owner for products purchased for home use within the USA. If the product is located in an area where service by a GE Appliances Authorized Servicer is not available, you may be responsible for a trip charge or you may be required to bring the product to an Authorized GE Appliances Service location for service. In Alaska, the warranty excludes the cost of shipping or service calls to your home.

Some states do not allow the exclusion or limitation of incidental or consequential damages. This warranty gives you specific legal rights, and you may also have other rights which vary from state to state. To know what your legal rights are, consult your local or state consumer affairs office or your state's Attorney General.

**Warrantor: General Electric Company, Louisville, KY 40225**

# Performance Data Sheet

## SmartWater™ Filtration System—GE Appliances MWF Cartridge

The concentration of the indicated substances in water entering the system was reduced to a concentration less than or equal to the permissible limit for water leaving the system as specified in NSF/ANSI Standard 42 and Standard 53. System tested and certified by NSF International against NSF/ANSI Standard 42 and Standard 53 for the reduction of substances listed below.

### Capacity 300 Gallons (1,135 Liters). Contaminant Reduction Determined by NSF testing.

Substance Tested for Reduction	Average Influent	NSF specified Challenge Concentration	Avg % Reduction	Average Product Water Concentration	Max Permissible Product Water Concentration	NSF Reduction Requirements	NSF Test Report
Chlorine Taste and Odor	2.0 mg/L	2.0 mg/L ± 10%	97.5%	0.05 mg/L	N/A	≥ 50%	J-00077703
Nominal Particulate Class I, ≥0.5 to < 1.0 µm	7,833,333 pts/mL	At least 10,000 particles/mL	99.7%	18,617 pts/mL	N/A	≥85%	J-00077704
Cyst*	101,000 cysts/L	Minimum 50,000 cysts/L	99.99%	1 cyst/L	N/A	≥99.95%	J-00100036
Asbestos	47 MF/L	107 to 108 fibers/L; fibers greater than 10 µm in length	>99%	<1 MF/L	N/A	≥99%	J-00077707
Atrazine	0.009 mg/L	0.009 mg/L ± 10%	94.5%	0.0005 mg/L	0.003 mg/L	N/A	J-00077708
Benzene	0.016 mg/L	0.015 mg/L ± 10%±	96.7%	0.0005 mg/L	0.005 mg/L	N/A	J-00077717
Carbofuran	0.08 mg/L	0.08 mg/L ± 10%	98.7%	0.001 mg/L	0.04 mg/L	N/A	J-00077718
Endrin	0.007 mg/L	0.006 mg/L ± 10%	97.1%	0.0002 mg/L	0.002 mg/L	N/A	J-00100039
Lead @ pH 6.5	0.152 mg/L	0.15 mg/L ± 10%	99.3%	0.001 mg/L	0.010 mg/L	N/A	J-00077722
Lead @ pH 8.5	0.148 mg/L	0.15 mg/L ± 10%	99.3%	0.001 mg/L	0.010 mg/L	N/A	J-00077723
Lindane	0.002 mg/L	0.002 mg/L ± 10%	99.0%	0.00002 mg/L	0.0002 mg/L	N/A	J-00077726
Mercury @ pH 6.5	0.0058 mg/L	0.006 mg/L ± 10%	93.2%	0.0004 mg/L	0.002 mg/L	N/A	J-00100037
Mercury @ pH 8.5	0.0061 mg/L	0.006 mg/L ± 10%	93.2%	0.0004 mg/L	0.002 mg/L	N/A	J-00092355
P-Dichlorobenzene	0.222 mg/L	0.225 mg/L ± 10%	99.8%	0.005 mg/L	0.075 mg/L	N/A	J-00077729
Tetrachloroethylene	0.015 mg/L	0.015 mg/L ± 10%	96.7%	0.0005 mg/L	0.005 mg/L	N/A	J-00082184
Toxaphene	0.015 mg/L	0.015 mg/L ± 10%	93.2%	0.001 mg/L	0.003 mg/L	N/A	J-00077730
2,4-D	0.218 mg/L	0.210 mg/L ± 10%	99.5%	0.0009 mg/L	0.07 mg/L	N/A	J-00085470

\*Based on the use of Cryptosporidium parvum oocysts.

The following pharmaceutical reduction claims have not been certified by NSF International or the state of California. Claims tested and verified by independent laboratory:

Contaminant Reduction	Average Influent	NSF specified Challenge Concentration	Avg % Reduction	Average Product Water Concentration	Max Permissible Product Water Concentration	NSF Reduction Requirements	NSF Test Report
Atenolol	978 ng/L	N/A	99.5%	5.0 ng/L	N/A	N/A	J-00121587
Fluoxetine	907 ng/l	N/A	99.4%	5.4 ng/L	N/A	N/A	J-00121587
Ibuprofen	885 ng/L	N/A	94.1%	52.3 ng/L	N/A	N/A	J-00121588
Progesterone	1097 ng/L	N/A	99.5%	5.0 ng/L	N/A	N/A	J-00121589
Trimethoprim	415 ng/L	N/A	99.5%	2.0 ng/L	N/A	N/A	J-00121587

### Application Guidelines/Water Supply Parameters

Service Flow	0.5 gpm (21.9 lpm)	Water Pressure	40-120 psi (2.8-8.2 bar)
Water Supply	Potable Water	Water Temperature	33°F-100°F (0.6°C-38°C)

It is essential that the manufacturer's recommended installation, maintenance and filter replacement requirements be carried out for the product to perform as advertised. See Installation Manual for Warranty information.

**Note:** While the testing was performed under standard laboratory conditions, actual performance may vary.  
Replacement Cartridge: MWF. For estimated costs of replacement elements please call 1-800-626-2002 or visit our website at [www.geapplianceparts.com](http://www.geapplianceparts.com).

### WARNING

To reduce the risk associated with ingestion of contaminants:

- Do not use with water that is microbiologically unsafe or of unknown quality without adequate disinfection before and after the system. Systems certified for cyst reduction may be used on disinfected water that may contain filterable cysts. EPA Establishment Number 10350-MN-005.

For conditions of use, health claims certified by the California Department of Public Health, and replacements, see performance data sheet. California Department of Public Health Certification #05-1698. The contaminants or other substances removed or reduced by this water filter are not necessarily in all users' water.

### NOTICE

To reduce the risk associated with property damage due to water leakage:

- Read and follow use instructions before installation and use of this system.
- Installation and use **MUST** comply with all state and local plumbing codes.
- Do not install if water pressure exceeds 120 psi (8.2 bar). If your water pressure exceeds 80 psi, you **must** install a pressure-limiting valve. Contact a plumbing professional if you are uncertain how to check your water pressure.
- Do not install where water hammer conditions may occur. If water hammer conditions exist you **must** install a water hammer arrester. Contact a plumbing professional if you are uncertain how to check for this condition.
- Do not install on hot water supply lines. The maximum operating water temperature of this filter system is 100° F (38° C).
- Protect filter from freezing. Drain filter when temperatures drop below 33°F (0.6°C).
- The disposable filter cartridge **must** be replaced every 6 months at the rated capacity, or sooner if a noticeable reduction in flow rate occurs.



Tested and certified by NSF International against NSF/ANSI Standard 42 and Standard 53 in model GE Appliances MWF for the reduction of the claims specified on the performance data sheet.

# MWF Water Filter Cartridge Limited Warranty

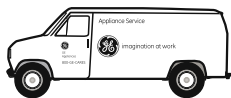

Contact us at [www.geapplianceparts.com](http://www.geapplianceparts.com)  
(Canada [geappliances.ca](http://geappliances.ca))  
or call 800.GE.CARES (Canada 1.800.561.3344).

Staple your receipt here. Proof of the original purchase date is needed to obtain service under the warranty.

## For The Period Of:

## We Will Replace, At No Charge To You:

### Thirty Days

From the date of the original purchase

**Any part** of the water filter cartridge which fails due to a defect in materials or workmanship during this **limited thirty-day warranty**.\*

## What is Not Covered:

- Service trips to your home to teach you how to use the product.
- Improper installation.
- Failure of the product if it is abused, misused, used for other than the intended purpose or used commercially.
- Replacement of house fuses or resetting of circuit breakers.
- Replacement of the water filter cartridge due to water pressure that is outside the specified operating range or due to excessive sediment in the water supply.
- Damage to the product caused by accident, fire, floods or acts of God.
- Incidental or consequential damage caused by possible defects with this appliance.

*This warranty is extended to the original purchaser and any succeeding owner for products purchased for home use within the USA. In Alaska, the warranty excludes the cost of shipping or service calls to your home.*

*Some states do not allow the exclusion or limitation of incidental or consequential damages. This warranty gives you specific legal rights, and you may also have other rights which vary from state to state. To know what your legal rights are, consult your local or state consumer affairs office or your state's Attorney General.*

**For Purchases Made In Iowa:** This form must be signed and dated by the buyer and seller prior to the consummation of this sale.

This form should be retained on file by the seller for a minimum of two years.

### Buyer:

Name \_\_\_\_\_

Address \_\_\_\_\_

City \_\_\_\_\_ State \_\_\_\_\_ Zip \_\_\_\_\_

Signature \_\_\_\_\_ Date \_\_\_\_\_

### Seller:

Name \_\_\_\_\_

Address \_\_\_\_\_

City \_\_\_\_\_ State \_\_\_\_\_ Zip \_\_\_\_\_

Signature \_\_\_\_\_ Date \_\_\_\_\_

\* If your GE Appliances part fails because of a manufacturing defect within thirty days from the date of original purchase for use, we will give you a new or, at our option, a rebuilt part without charge. Return the defective part to the parts supplier from whom it was purchased together with a copy of the "proof of purchase" for the part. If the part is defective and shows no signs of abuse, it will be exchanged. The warranty does not cover the failure of parts which are damaged while in your possession, are abused, or have been installed improperly. It does not cover the cost of returning the part to the supplier from whom it was purchased nor does it cover the cost of labor to remove or install it to diagnose the fault. It does not cover parts used in products in commercial use except in the case of air conditioning equipment. In no event shall GE Appliances be liable for consequential damages. Warranter: GE Appliances

EXCLUSION OF IMPLIED WARRANTIES: Your sole and exclusive remedy is part exchange as provided in this Limited Warranty. Any implied warranties, including the implied warranties of merchantability or fitness for a particular purpose, are limited to six months or the shortest period allowed by law.



### GE APPLIANCES

Appliance Park  
Louisville, KY 40225  
[gewaterfilters.com](http://gewaterfilters.com)

## Consumer Support.

---



### GE Appliances Website

In the U.S.: *GEAppliances.com*

Have a question or need assistance with your appliance? Try the GE Appliances website, 24 hours a day, any day of the year! For greater convenience and faster service, you can now download Owner's Manuals, order parts or even schedule service on-line. In Canada: [www.GEAppliances.ca](http://www.GEAppliances.ca)

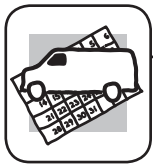

### Schedule Service

In the U.S.: *GEAppliances.com*

Expert GE Appliances repair service is only one step away from your door. Get on-line and schedule your service at your convenience any day of the year! Or call 800.GE.CARES (800.432.2737) during normal business hours.

In Canada, call 1.800.561.3344



### Real Life Design Studio

In the U.S.: *GEAppliances.com*

GE Appliances supports the Universal Design concept—products, services and environments that can be used by people of all ages, sizes and capabilities. We recognize the need to design for a wide range of physical and mental abilities and impairments. For details of GE's Universal Design applications, including kitchen design ideas for people with disabilities, check out our Website today. For the hearing impaired, please call 800.TDD.GEAC (800.833.4322).

In Canada, contact: Manager, Consumer Relations, Mabe Canada Inc.  
Suite 310, 1 Factory Lane  
Moncton, N.B. E1C 9M3



### Extended Warranties

In the U.S.: *GEAppliances.com*

Purchase a GE extended warranty and learn about special discounts that are available while your warranty is still in effect. You can purchase it on-line anytime, or call 800.626.2224 during normal business hours. GE Appliances Consumer Home Services will still be there after your warranty expires. In Canada, call 1.888.261.2133

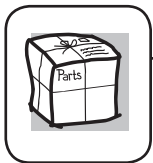

### Parts and Accessories

In the U.S.: *GEApplianceParts.com*

Individuals qualified to service their own appliances can have parts or accessories sent directly to their homes (VISA, MasterCard and Discover cards are accepted). Order on-line today, 24 hours every day or by phone at 800.626.2002 during normal business hours. (In Canada, call 1.800.661.1616.)

Instructions contained in this manual cover procedures to be performed by any user. Other servicing generally should be referred to qualified service personnel. Caution must be exercised, since improper servicing may cause unsafe operation.

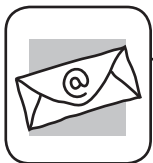

### Contact Us

In the U.S.: *GEAppliances.com*

If you are not satisfied with the service you receive from GE, contact us on our Website with all the details including your phone number, or write to:

General Manager, Customer Relations  
GE Appliances, Appliance Park  
Louisville, KY 40225

In Canada: [www.GEAppliances.ca](http://www.GEAppliances.ca), or call 1.800.661.1616 or write to: Director, Consumer Relations, MC Commercial  
Suite 310, 1 Factory Lane  
Moncton, N.B. E1C 9M3



### Register Your Appliance

In the U.S.: *GEAppliances.com*

Register your new appliance on-line—at your convenience! Timely product registration will allow for enhanced communication and prompt service under the terms of your warranty, should the need arise. You may also mail in the pre-printed registration card included in the packing material. In Canada: [www.GEAppliances.ca](http://www.GEAppliances.ca)