

Installation Instructions

Washer

If you have any questions, call GE Appliances at 800.GE.CARES (800.432.2737) or visit our Website at: GEAppliances.com
In Canada, call 800.561.3344 or visit GEAppliances.ca

BEFORE YOU BEGIN

Read these instructions completely and carefully.

- **IMPORTANT** — Save these instructions for local inspector's use.
- **IMPORTANT** — Observe all governing codes and ordinances.
- **Note to Installer** — Be sure to leave these instructions with the Consumer.
- **Note to Consumer** — Keep these instructions for future reference.
- **Skill level** — Installation of this appliance requires basic mechanical and electrical skills.
- **Completion time** — 1-3 hours
- Proper installation is the responsibility of the installer.
- Product failure due to improper installation is not covered under the Warranty.

LOCATION OF YOUR WASHER

DO NOT Install the Washer:

1. In an area exposed to dripping water or outside weather conditions. The ambient temperature should never be below 60°F (15.6°C) for proper washer operation.
2. In an area where it will come in contact with curtains or drapes.
3. On carpet. The floor **MUST** be a hard surface with a maximum slope of 1/2" per foot (1.27 cm per 30 cm). To make sure the washer does not vibrate or move, you may have to reinforce the floor.

NOTE: If floor is in poor condition, use 3/4" impregnated plywood sheet solidly attached to existing floor covering.

MOBILE HOME INSTALLATION:

Installation must conform to Standard for Mobile Homes, ANSI A119.1 and National Mobile Home Construction and Safety Standards Act of 1974 (PL93-383).

TOOLS REQUIRED

- Level
- Adjustable wrench



- Channel-lock adjustable pliers



- Phillips screwdriver



PARTS SUPPLIED

- Shipping Bolt Covers (4)
- Drain Hose Guide

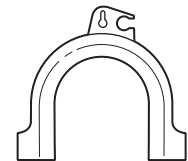

- Lock Bar - Retain for Reversing the Door Swing (optional on some models only)



- Cable Tie



PARTS REQUIRED (Sold separately or included with the GFW510 model)

- Water Hoses (2)
- Rubber Washers (2) and Strainer Screens (2)



GE Appliances Parts and Accessories

Order on-line at GEApplianceparts.com today, 24 hours a day or by phone at 877.959.8688 during normal business hours. In Canada, visit your local GE Appliances parts distributor or call 800.661.1616 or GEAppliances.ca/en/products/parts-filters-accessories.

Part Number Accessory

WX14X10011 6 ft stainless steel washer hoses with 90° elbows; 2-pack

WH1X2267 Rubber Washer (1) and Screen (1)

Installation Instructions

WASHER DIMENSIONS

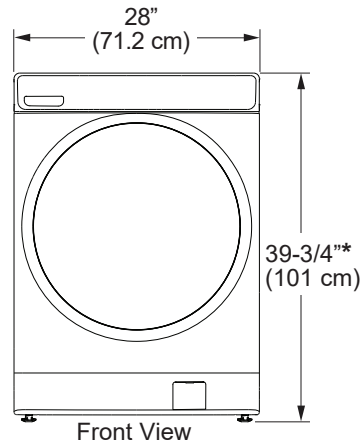

Models - PFW950, PFW870:

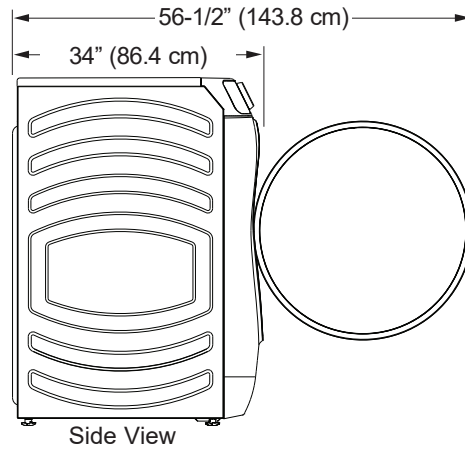

Models - GFW655, GFW650, GFW550, GFW510:

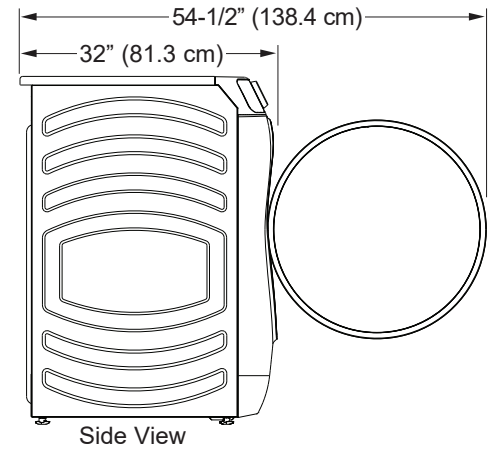

*With leveling legs retracted: 39-3/4 (101 cm). / With leveling legs fully extended: 40-5/8 (103.1 cm).

MINIMUM CLEARANCES

Alcove or Closet

- Rear = 0"
- Sides = 0"
- Top = 0"
- Front = 0"

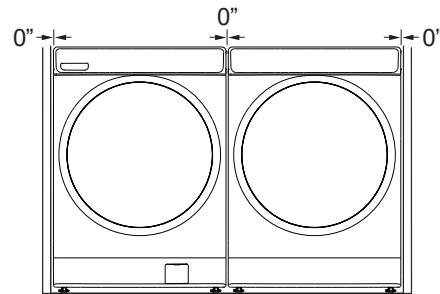
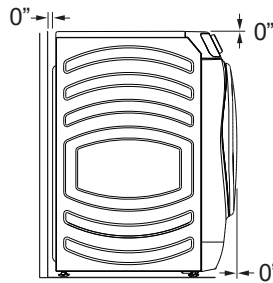

- Consideration must be given to provide adequate clearance for installation and service.
 - Closet doors must be louvered or otherwise ventilated and have at least 60 square inches (387.1 cm²) of open area. If the closet contains both a washer and a dryer, doors must contain a minimum of 120 square inches (774.2 cm²) of open area.
- *To enable 0" clearance on the back of the washer, you must use 90° elbow hoses. Otherwise you may require some additional clearance to avoid rubbing of the hoses against the back wall.

ACCESSORIES:

Order on-line at GEApplianceparts.com, 24 hours a day or by phone at 877.959.8688 during normal business hours.

Part Number	Accessory
GFR0728SNWW	White Riser
GFR0728PNSN	Satin Nickel Riser
GFR0728PNRS	Royal Sapphire Riser
GFR0728PNDG	Diamond Gray Riser
GFR0728PTDS	Black Slate Riser
GFP1528SNWW	White Pedestal
GFP1528PNSN	Satin Nickel Pedestal
GFP1528PNRS	Royal Sapphire Pedestal
GFP1528PNDG	Diamond Gray Pedestal
GFP1528PTDS	Black Slate Pedestal
GFA28KITN	Stacking Kit for Dryer over Washer

Riser:

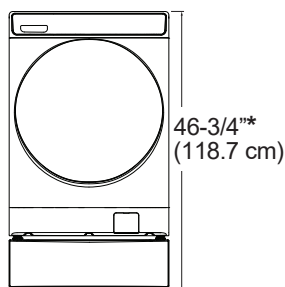

Pedestal:

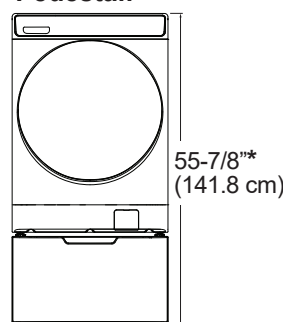

Stacked:

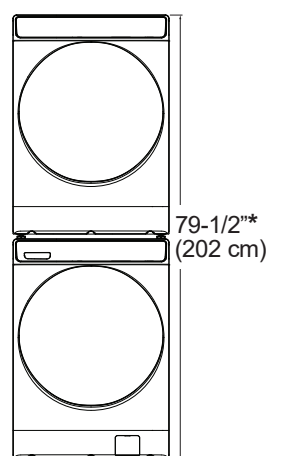

Follow the **Installation Instructions** included in the Kit for all clearances and installation requirements.

*With leveling legs retracted. See the **WASHER DIMENSIONS** section above for legs extension dimensions.

Installation Instructions

UNPACKING THE WASHER

▲ WARNING Recycle or destroy the carton and plastic bags after the washer is unpacked. Make materials inaccessible to children. Children might use them for play. Cartons covered with rugs, bedspreads or plastic sheets can become airtight chambers causing suffocation.

1. Cut and remove all packaging straps.
2. While it is in the carton, carefully lay the washer on its side. DO NOT lay the washer on its front or back.
3. Turn down the bottom flaps. Remove all base packaging including the styrofoam base.
4. Carefully return the washer to an upright position and remove the carton by lifting it upward.
5. Carefully move the washer to within 4 feet (122 cm) of the final location.
6. Remove the following from the back side of the washer:
 - 4 bolts
 - 4 plastic spacers (including power cord retainers and rubber grommets)
 - 1 bracket and the screws fastening it to the washer

NOTE: Do NOT remove the screw or clip holding the hose.

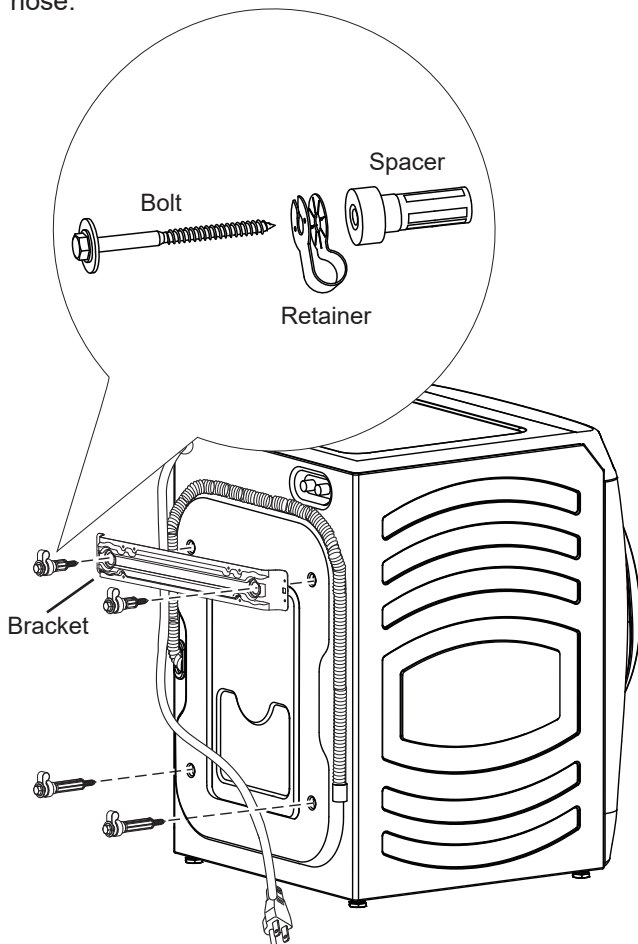

UNPACKING THE WASHER (cont.)

7. Insert shipping bolt hole covers into shipping bolt holes.

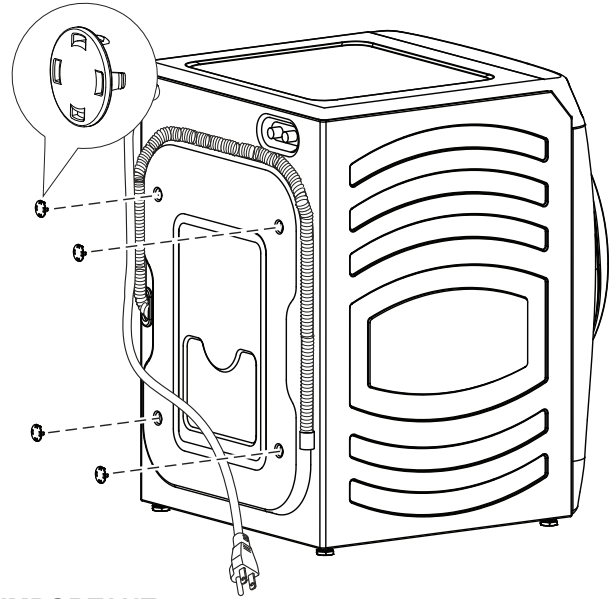

IMPORTANT:

- Failure to remove all shipping support hardware can cause the washer to become severely unbalanced.
- Save all shipping support hardware for future use. If you must transport the washer at a later date, you must reinstall the shipping bolts and spacers to prevent shipping damage. The bracket is not required and can be discarded.

NOTE: Consider recycling options for your appliance packaging material.

Installation Instructions

ELECTRICAL REQUIREMENTS

⚠ WARNING - Electrical Shock Hazard

Plug into a grounded 3-prong outlet.

DO NOT remove ground prong.

DO NOT use an adapter.

DO NOT use an extension cord.

Failure to follow these instructions can result in death, fire or electrical shock.

CIRCUIT – Individual, properly polarized and grounded 15 or 20 amp circuit breaker or time-delay fuse.

POWER SUPPLY – 2 wire plus ground, 120 Volt, single phase, 60 Hz, alternating current.

Outlet Receptacle – Properly grounded 3-prong receptacle to be located so the power cord is accessible when the washer is in an installed position. If a 2-prong receptacle is present, it is the owner's responsibility to have a licensed electrician replace it with a properly grounded 3-prong grounding type receptacle.

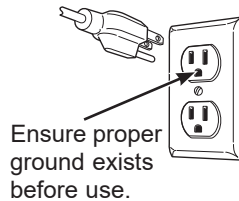

Washer must be electrically grounded in accordance with local codes and ordinances, or in the absence of local codes, with latest edition of the NATIONAL ELECTRICAL CODE, ANSI/NFPA NO. 70 or CANADIAN ELECTRICAL CODE, CSA C22.1. Check with a licensed electrician if you are not sure that the washer is properly grounded.

GROUNDING INSTRUCTIONS

This appliance must be grounded. In the event of malfunction or breakdown, grounding will reduce the risk of electric shock by providing a path of least resistance for electric current. This appliance is equipped with a cord having an equipment-grounding conductor and a grounding plug. The plug must be plugged into an appropriate outlet that is properly installed and grounded in accordance with all local codes and ordinances.

⚠ WARNING Improper connection of the equipment-grounding conductor can result in a risk of electrical shock. Check with a qualified electrician, or service representative or personnel, if you are in doubt as to whether the appliance is properly grounded. **DO NOT** modify the plug on the power supply cord. If it will not fit the outlet, have a proper outlet installed by a qualified electrician.

If required by local codes, an external 18 gauge or larger copper ground wire (not provided) may be added. Attach to washer cabinet with a #10-16 x 1/2" sheet metal screw (available at any hardware store) to rear of washer.

⚠ WARNING - Electrical Shock Hazard

Disconnect power supply before servicing.

Replace all parts and panels before operating.

Failure to do so can result in death or electrical shock.

⚠ WARNING - Shock Hazard

Certain internal parts are intentionally not grounded and may present a risk of electric shock only during servicing.

Service personnel – DO NOT contact the following parts while the appliance is energized: water valve, drain pump, NTC, heater, door lock, inverter board, motor and MC board.

WATER SUPPLY REQUIREMENTS

The faucets **MUST** be 3/4" (1.9 cm) garden hose-type so inlet hoses can be connected. Water pressure **MUST** be between 10 and 120 pounds per square inch. Your water department can advise you of your water pressure. The hot water temperature should be set to deliver water at 120° to 140°F (48°–60°C) to provide proper Automatic Temperature Control (ATC) performance.

DRAIN REQUIREMENTS

1. Drain capable of eliminating 10 gallons (38 L) per minute.
2. A standpipe diameter of 1-1/4" (3.18 cm) minimum.
3. The standpipe height above the floor should be:
Minimum height: 24" (61 cm)
Maximum height: 96" (244 cm)

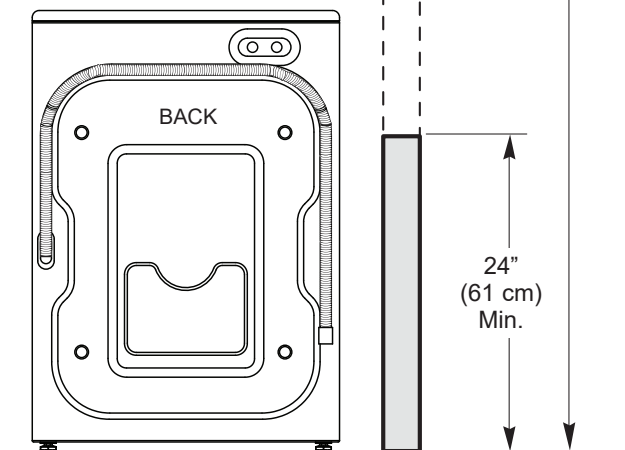

Installation Instructions

INSTALLING THE WASHER

1. Run some water from the hot and cold faucets to flush the water lines and remove particles that might clog the inlet hose and water valve screens.
2. Remove the inlet hoses from the packaging (whether supplied with the washer or sold separately).

3. (90° elbow end) Ensure there is a rubber washer in the 90° elbow end of the HOT and COLD hoses. Reinstall the rubber washer into the hose fitting if it has fallen out during shipment. Carefully connect the inlet hose marked HOT to the outside "H" outlet of the water valve. Tighten by hand, then tighten another 2/3 turn with pliers. Carefully connect the other inlet hose to the inside "C" outlet of the water valve. Tighten by hand; then tighten another 2/3 turn with pliers. **Do not crossthread or over-tighten these connections.**

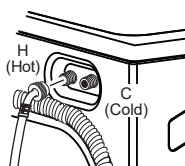

4. If inlet hose screen washers are not already inserted into the inlet hoses, install them by inserting into the free ends of the HOT and COLD inlet hoses with protruded side facing the faucet.
5. Connect the inlet hose ends to the HOT and COLD water faucets tightly by hand, then tighten another 2/3 turn with pliers. Turn the water on and check for leaks.

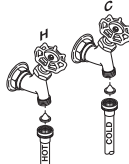

6. Carefully move the washer to its final location. Gently rock the washer into position. It is important not to damage the rubber leveling legs when moving your washer to its final location. Damaged legs can increase washer vibration. It may be helpful to spray window cleaner on the floor to help move your washer into its final position.

NOTE: To reduce vibration, ensure that all four rubber leveling legs are firmly touching the floor. Push and pull on the back right and then back left of your washer.

NOTE: Do not use the dispenser drawer or door to lift the washer.

NOTE: If you are installing into a drain pan, you can use a 24-inch long 2x4 to lever the washer into place.

7. With the washer in its final position, place a level on top of the washer (if the washer is installed under a counter, the washer should not be able to rock). Adjust the front leveling legs up or down to ensure the washer is resting solidly. Turn the lock nuts on each leg up toward the base of the washer and snug with a wrench.

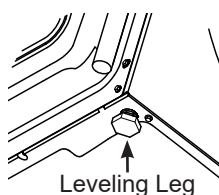

NOTE: Keep the leg extension at a minimum to prevent excessive vibration. The farther out the legs are extended, the more the washer will vibrate.

If the floor is not level or is damaged, you may have to extend the rear leveling legs.



INSTALLING THE WASHER (cont.)

8. Attach U-shaped hose guide to the end of the drain hose. Place the hose in a laundry tub or standpipe and secure it with the cable tie provided in the enclosure package.

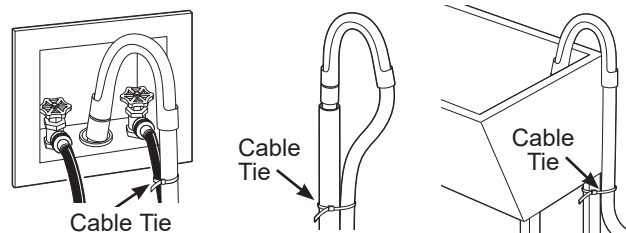

NOTE: Placing the drain hose too far down the drain pipe can cause a siphoning action. No more than 7 inches of hose should be in the drain pipe. There must be an air gap around the drain hose. A snug fit can cause a siphoning action.

9. Plug the power cord into a grounded outlet.
NOTE: Check to be sure the power is off at the circuit breaker/fuse box before plugging the power cord into an outlet.
10. Turn on the power at the circuit breaker/fuse box.
11. Read the rest of this Owner's Manual. It contains valuable and helpful information that will save you time and money.
12. **Before starting the washer, check to make sure:**
 - Main power is turned on.
 - The washer is plugged in.
 - The water faucets are turned on.
 - The unit is level and all four leveling legs are firmly on the floor.
 - The shipping support hardware is removed and saved.
 - The drain hose is properly tied up.
 - There are no leaks at the faucet, drain line or washer.
13. Run the washer through a complete cycle. Check for water leaks and proper operation.
14. If your washer does not operate, please review the Before You Call For Service section before calling for service.
15. Place these instructions in a location near the washer for future reference.

REPLACEMENT PARTS

If replacement parts are needed for your washer, they can be ordered in the United States by visiting our Website at GEApplianceparts.com or by calling GE Appliances at 877.959.8688. In Canada, visit GEAppliances.ca/en/products/parts-filters-accessories or call 800.661.1616.

Installation Instructions

REVERSING THE DOOR SWING (OPTIONAL ON SOME MODELS ONLY)

⚠ WARNING

Unplug the appliance or turn off the circuit breaker before servicing. Pressing the **Power** pad **DOES NOT** disconnect power.

⚠ WARNING - Shock Hazard

Certain internal parts are intentionally not grounded and may present a risk of electric shock only during servicing.

Service personnel – DO NOT contact the following parts while the appliance is energized: water valve, drain pump, NTC, heater, door lock, inverter board, motor and MC board.

TOOL YOU WILL NEED

- Phillips-head screwdriver

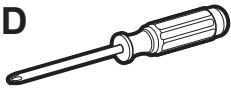

1 REMOVE THE DOOR ASSEMBLY

- Open the washer door.
- While supporting the door, remove the 4 screws from the hinge in the washer face.
- Lift the door assembly to remove it from the washer face and set it on a protective surface.

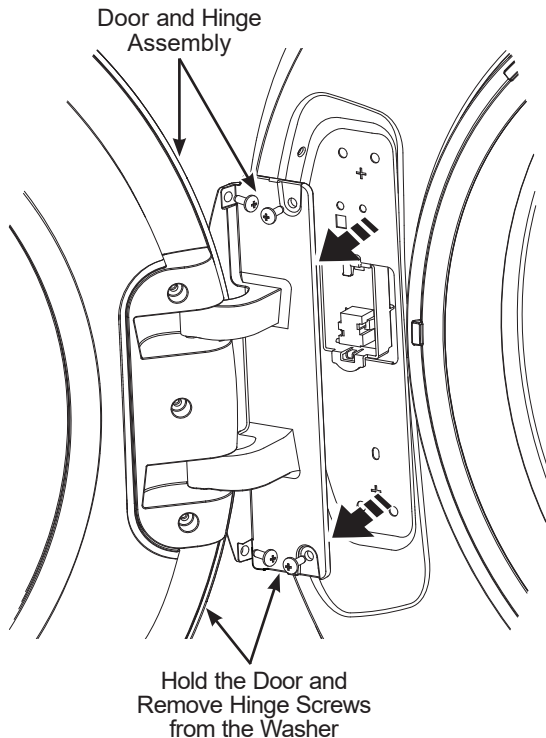

IMPORTANT NOTES

- Handle parts carefully to avoid scratching paint.
- Provide a non-scratching work surface for the door.
- Set screws down by their related parts to avoid using them in the wrong places.
- Once you begin, do not move the cabinet until door-swing reversal is completed.
- These instructions are for changing the hinges from the left side to the right side—if you ever want to switch them back to the right side, follow these same instructions and reverse all references to the left and right.

Video



Scan this code to watch a video on this topic.

PART SUPPLIED

- Lock Bar

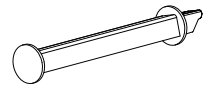

2 REMOVE THE DOOR HINGE COVER AND THE DOOR HINGE

- Remove the 3 screws from the hinge cover and remove the cover.
- Remove the 6 screws from the hinge and remove the hinge from the door.

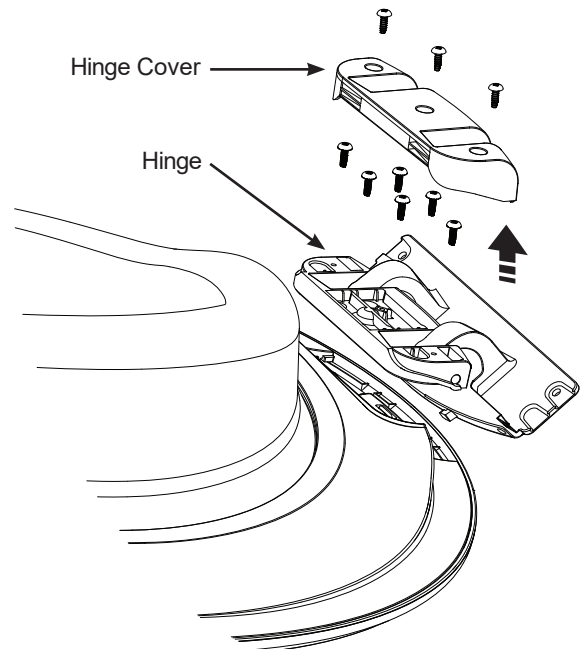

Installation Instructions

REVERSING THE DOOR SWING (OPTIONAL ON SOME MODELS ONLY)

3 REMOVE, REVERSE AND REPLACE THE DOOR STRIKER

- Remove the 2 screws from the striker. Rotate the striker 180° and reinstall the striker with its screws.

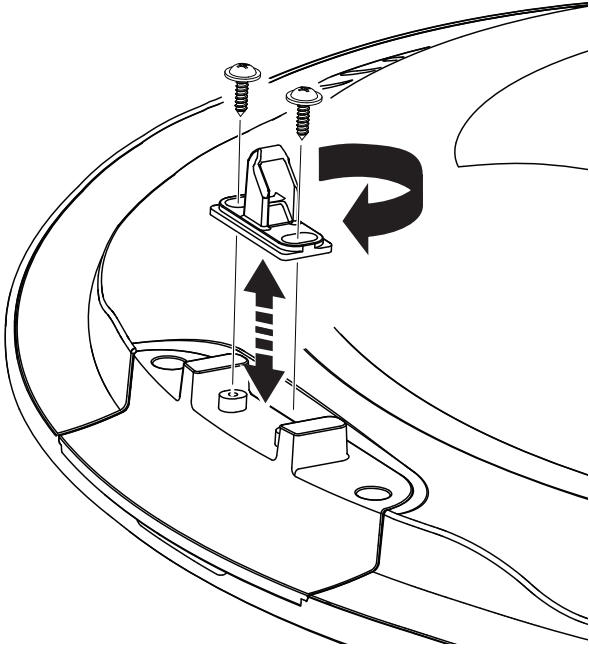

4 REMOVE THE DOOR STRIKER ASSEMBLY AND REPLACE ON THE OPPOSITE SIDE (CONTINUED)

- Rotate the striker assembly and replace it on the opposite side with its screws.

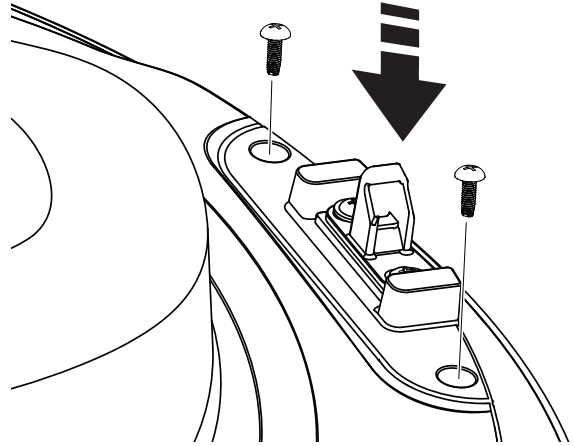

4 REMOVE THE DOOR STRIKER ASSEMBLY AND REPLACE ON THE OPPOSITE SIDE

- Remove the 2 screws from the striker assembly and remove the assembly by pulling it toward the center, pushing it up and pulling it out.

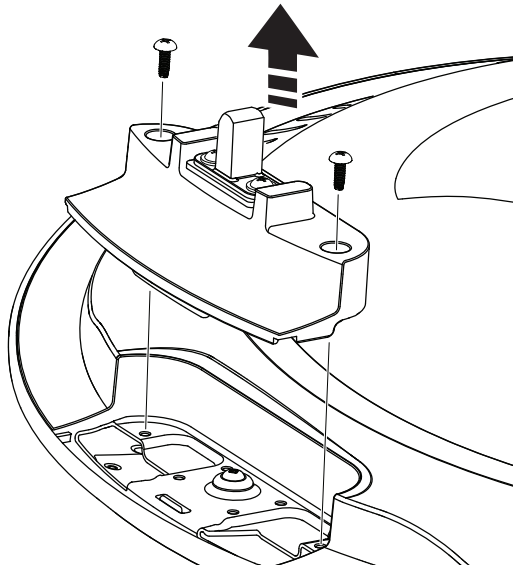

5 REPLACE THE DOOR HINGE AND THE DOOR HINGE COVER ON THE OPPOSITE SIDE

- Rotate the door hinge and replace it on the opposite side with its screws.
- Rotate the door hinge cover and replace it on the opposite side with its screws.

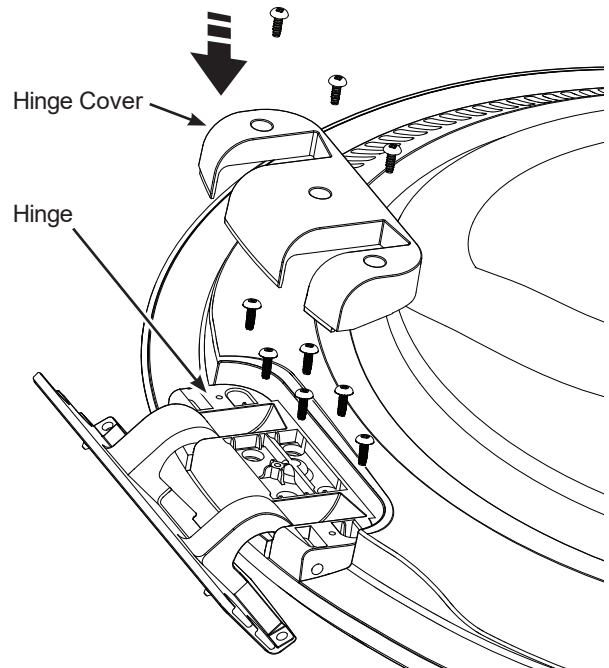

Installation Instructions

REVERSING THE DOOR SWING (OPTIONAL ON SOME MODELS ONLY)

6 REMOVE THE TERMINAL HOLDER AND DISCONNECT THE PIN CONNECTOR FROM WASHER

- Using your fingers, pry the terminal holder from the washer face.
- Disconnect the pin connector.

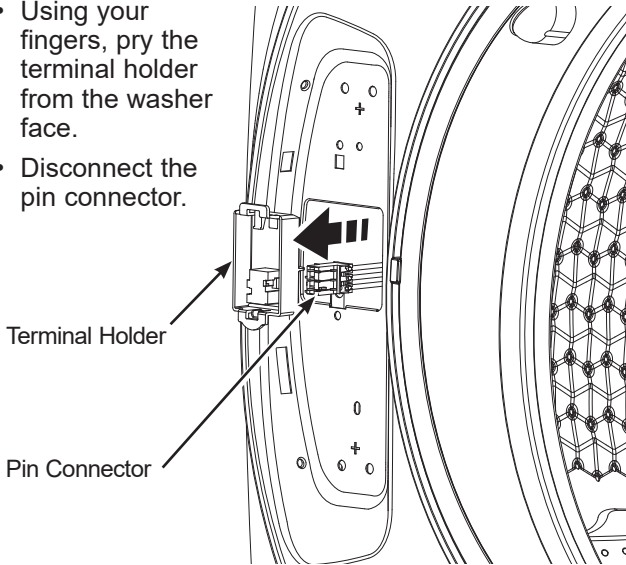

7 REMOVE LOCK ASSEMBLY AND INSTALL ON OPPOSITE SIDE OF WASHER

- Remove the 2 screws from the lock cover plate and remove it from the washer face.

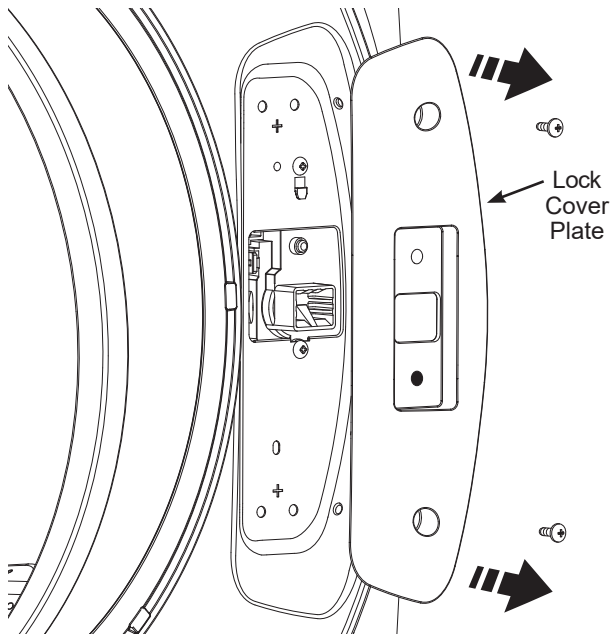

7 REMOVE LOCK ASSEMBLY AND INSTALL ON OPPOSITE SIDE OF WASHER (CONTINUED)

- Insert the provided lock bar into the lock mechanism in the washer face. Remove the lock assembly by removing its two screws, using the lock bar to lift it up to unhook, tilting and pulling it out of the washer face. Disconnect its pin connector by unsnapping its locks.

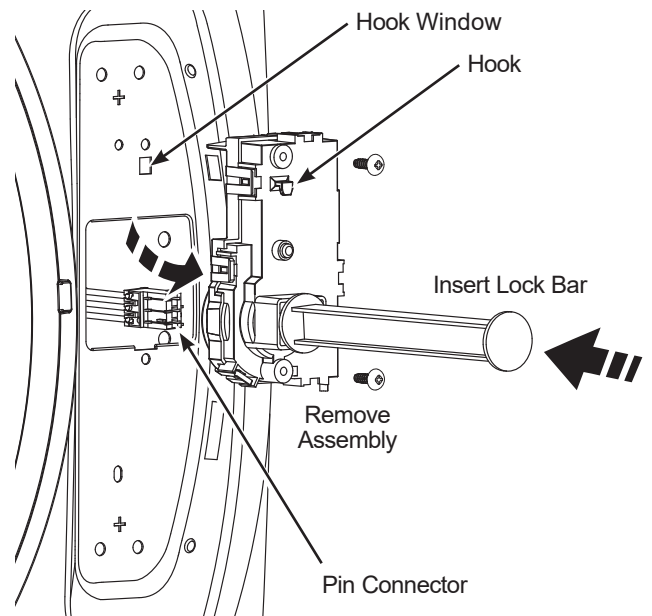

- Do **NOT** rotate lock assembly. Move it to the opposite side of the washer and connect the pin connector making sure it is fully snap locked together. Tilt and insert the lock assembly into the washer face, lift it up and latch its hook into its window. Replace its screws. Remove the lock bar from the assembly and retain for future use.

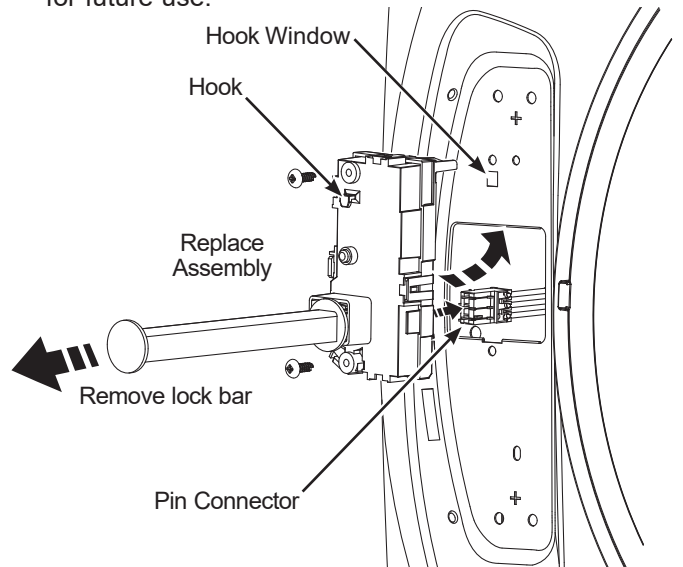

Installation Instructions

REVERSING THE DOOR SWING (OPTIONAL ON SOME MODELS ONLY)

7 REMOVE LOCK ASSEMBLY AND INSTALL ON OPPOSITE SIDE OF WASHER (CONTINUED)

- Remove the lock switch cover button from the back of the lock cover plate and replace it in the opposite hole in the lock cover plate.

NOTE: The cover button must be reinstalled into the lower hole in the lock cover plate as shown.

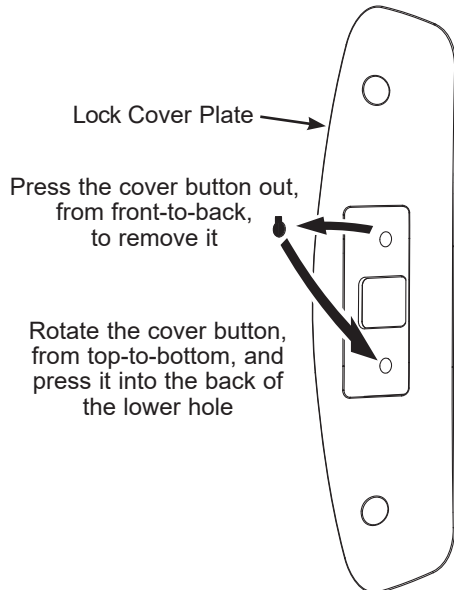

- Install the lock cover plate over the lock assembly, making sure that the lock switch operates freely. Replace its screws.

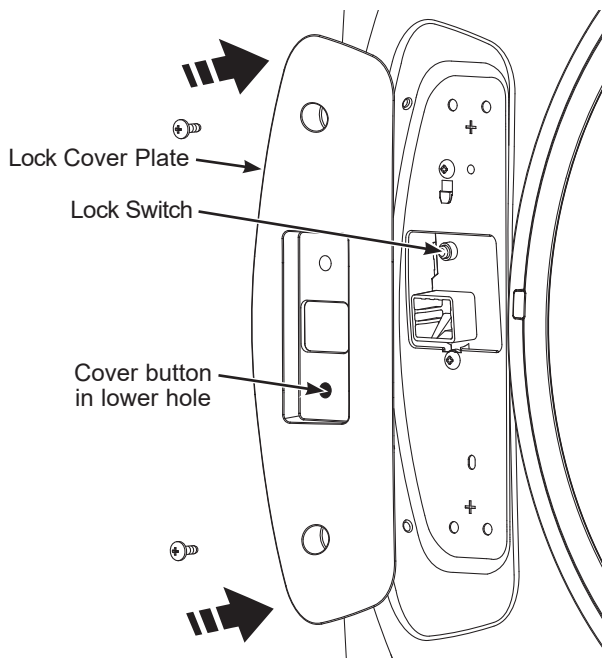

8 RECONNECT PIN CONNECTOR FROM THE WASHER AND REPLACE THE TERMINAL HOLDER

- Reconnect the pin connector and press the terminal holder back into the washer face on the opposite side.

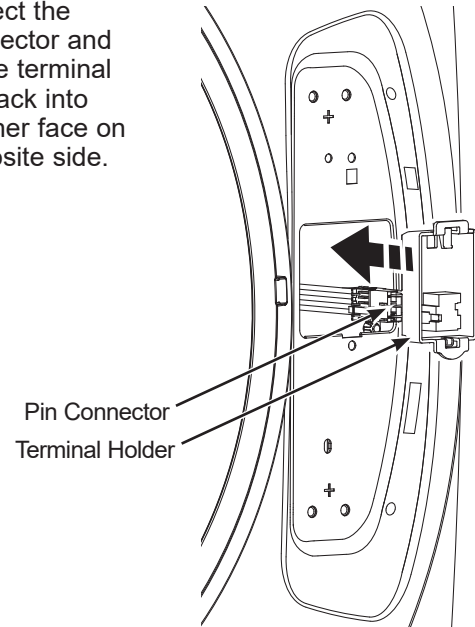

9 REPLACE THE DOOR ASSEMBLY

- Lift the door assembly into place and secure it onto washer face with its 4 screws.

Replace this screw first

Replace 4 screws into the hinge and secure into the washer face

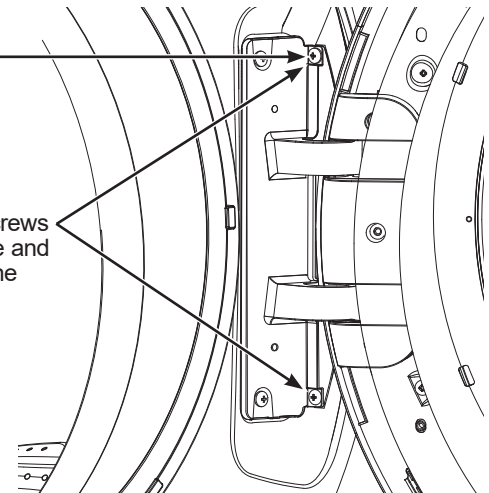

- Close the washer door.

NOTE: Make sure the door opens and closes correctly. If not, repeat all steps making sure all parts and screws are securely seated.

- Connect power cord and turn on the breaker.
- Run the washer through a complete cycle to verify proper operation.

Troubleshooting Tips... Before you call for service

It is highly recommended that you connect your washer to WiFi to download the latest software, receive periodic updates and benefit from many of the extended features available through the SmartHQ App. Many of the AI features for your washer require connection to the SmartHQ App. This may resolve some issues listed below.

Problem	Possible Cause	What To Do
Not draining Not spinning Not tumbling	Load is out of balance	Redistribute clothes and run Rinse & Spin . Increase load size if washing small load containing heavy and light items.
	Pump filter may be clogged	See the Care and Cleaning section on how to clean the Pump Filter .
	Drain hose is kinked or improperly connected	Straighten drain hose and make sure washer is not sitting on it.
	Household drain may be clogged	Check household plumbing. You may need to call a plumber.
	Drain hose siphoning; drain hose pushed too far down the drain	Ensure there is an air gap between hose and drain. Also, ensure the drain hose is not inserted more than 7" into the drain pipe.
Leaking water	Door gasket is damaged	Check to see if gasket is seated and not torn. Objects left in pockets may cause damage to the washer (nails, screws, pens, pencils) Water may drip from the door when the door is opened. This is a normal operation. Carefully wipe off rubber door seal. Sometimes dirt or clothing is left in this seal and can cause a small leak
	Check back left of washer for water	If this area is wet, you have oversudsing condition. Use less detergent.
	Fill hoses or drain hose is improperly connected	Make sure hose connections are tight at washer and faucets and make sure end of drain hose is correctly inserted in and secured to drain facility.
	Household drain may be clogged	Check household plumbing. You may need to call a plumber.
	Dispenser clogged	Powder soap may cause clogs inside the dispenser and cause water to leak out the front of the dispenser. Remove drawer and clean both drawer and inside of dispenser box. Laundry detergent packets should NOT be used in the dispenser. They should only be added directly to the wash basket following the manufacturer's directions. Please refer to Care and Cleaning section.
	Incorrect use of detergent	Use only HE and correct amount of detergent.
	Dispenser box cracked	If new installation, check for crack on inside of dispenser box.
Clothes too wet	Load is out of balance	Redistribute clothes and run Rinse & Spin .
		Increase load size if washing small load containing heavy and light items.
		The machine will slow the spin speed down to 410 rpm if it has a hard time balancing the load. This speed is normal.
	Pump filter may be clogged	See the Care and Cleaning section on how to clean the Pump Filter .
	Overloading	The dry weight of the load should be less than 16 lbs.
	Drain hose is kinked or improperly connected	Straighten drain hose and make sure washer is not sitting on it.
	Household drain may be clogged	Check household plumbing. You may need to call a plumber.
	Drain hose siphoning; drain hose pushed too far down the drain	Ensure there is an air gap between hose and drain. Also, ensure the drain hose is not inserted more than 7" into the drain pipe.

Troubleshooting Tips... Before you call for service

Problem	Possible Cause	What To Do
Incomplete cycle or timer not advancing	Automatic load redistribution	Timer adds up to 3 minutes to cycle for each rebalance. 11 or 15 rebalances may be done. This is normal operation. Do nothing; the machine will finish the wash cycle.
	Pump filter may be clogged	See the Care and Cleaning section on how to clean the Pump Filter .
	Drain hose is kinked or improperly connected	Straighten drain hose and make sure washer is not sitting on it.
	Household drain may be clogged	Check household plumbing. You may need to call a plumber.
	Drain hose siphoning; drain hose pushed too far down the drain	Ensure there is an air gap between hose and drain.
Loud or unusual noise; vibration or shaking	Cabinet moving	Washer is designed to move 1/4" to reduce forces transmitted to the floor. This movement is normal.
	All rubber leveling legs are not firmly touching the floor	Push and pull on the back right and then back left of your washer to check if it is level. If the washer is uneven, adjust the rubber leveling legs so they are all firmly touching the floor and locked in place.
	Unbalanced load	Pause unit, open door and manually redistribute load. To check machine, run rinse and spin with no load. If normal, unbalance was caused by load.
	Pump filter may be clogged	See the Care and Cleaning section on how to clean the Pump Filter .
No power/washer not working or dead	Washer is unplugged	Make sure cord is plugged securely into a working outlet.
	Water supply is turned off	Turn both hot and cold faucets fully on.
	Circuit breaker/fuse is tripped/blown	Check house circuit breakers/fuses. Replace fuses or reset breaker. Washer should have separate outlet.
	Automatic self system checks	First time the washer is plugged in, automatic checks occur. It may take up to 20 seconds before you can use your washer. This is normal operation.
"H2O SUPPLY" appears in display	Water not entering washer	See the Consumer Help Indicator section for details.
"CAnCELEd" appears in display	Washer paused or stopped	See the Consumer Help Indicator section for details.
"door" appears in display	Door not fully closed or 3 cycles started without opening door in between	See the Consumer Help Indicator section for details.
Snags, holes, tears, rips or excessive wear	Overloaded	Do not exceed maximum recommended load sizes. See recommended maximum load sizes in the Loading section.
	Pens, pencils, nails, screws or other objects left in pockets	Remove loose items from pockets.
	Pins, snaps, hooks, sharp buttons, belt buckles, zippers and sharp objects left in pockets	Fasten snaps, hooks, buttons and zippers.
Control time wrong or changes	This is normal	During spin the washer may need to rebalance the load sometimes to reduce vibrations. When this happens, the estimated time is increased causing time left to increase or jump.

Troubleshooting Tips... Before you call for service

Problem	Possible Cause	What To Do
Not enough water	This is normal	Horizontal washers do not require the tub to fill with water like top-load washers.
Washer pauses or has to be restarted, or washer door is locked and will not open	Pump filter may be clogged	See the Care and Cleaning section on how to clean the Pump Filter .
Door unlocks or press Start and machine doesn't operate	This is normal	Front-load washers start up differently than top-load washers, and it takes several seconds to check the system. The door will lock and unlock.
	Incorrect operation	Simply open and close the door firmly; then press Start .
	Control Lock On	Press and hold the Control Lock button for 3 seconds.
Water does not enter washer or enters slowly	Automatic self system checks	After Start is pressed, the washer does several system checks. Water will flow several seconds after Start is pressed.
	Water valve screens are stopped up	Turn off the water source and remove the water connection hoses from the upper back of the washer. Use a brush or toothpick to clean the screens in the machine. Reconnect the hoses and turn the water back on.
	Inlet hose screen washers are stopped up	Turn off the water source and remove the inlet hoses from the wall faucets. Use a brush or toothpick to clean the screen washers in the end of the hoses. Reconnect the hoses and turn the water back on.
	Pump filter may be clogged	See the Care and Cleaning section on how to clean the Pump Filter .
	Fill hoses may be kinked	Check that fill hoses are not kinked or clogged.
	Water supply is turned off	Turn on both hot and cold faucets fully.
	Energy efficiency	This is an energy-efficient washer. As a result, the temperature settings for this washer may be different than for a non-energy-efficient washer.
	Insufficient water supply	Make sure that the water supply is turned on. Make sure that the water faucets are turned to their completely open position.
	The washer door is open	The washer door must be closed for all washer cycle operations. If the door is opened during the washer operation, all functions will stop, including water filling.
	Incorrect fill hose connection	Make sure that the fill hoses connect the hot water supply to the hot inlet on the washer and the cold water supply to the cold inlet on the washer (hot to hot, cold to cold).
Wrinkling	Improper sorting	Avoid mixing heavy items (like work clothes) with light items (like blouses).
	Overloading	Load your washer so clothes have enough room to move freely.
	Incorrect wash cycle	Match cycle selection to the type of fabric you are washing (especially for easy care loads).
	Repeated washing in water that is too hot	Wash in warm or cold water.

Troubleshooting Tips... Before you call for service

Problem	Possible Cause	What To Do
Grayed or yellowed clothes	Not enough detergent	Use correct amount of detergent.
	Not using HE (high efficiency) detergent	Use only HE detergent.
	Hard water	Use hottest water safe for fabric.
		Use a water conditioner like Calgon brand or install a water softener.
	Water is not hot enough	Make sure water heater is delivering water at 120°–140°F (48°–60°C).
	Detergent is not dissolving or using too much fabric softener	Try a liquid HE detergent. Use less fabric softener.
Dye transfer	Sort clothes by color. If fabric label states wash separately, unstable dyes may be indicated.	
Colored spots	Incorrect use of fabric softener	Check fabric softener package for instructions and follow directions for using dispenser.
	Dye transfer	Sort whites or lightly colored items from dark colors.
		Promptly remove wash load from washer.
Water temperature is incorrect	Water supply is improperly connected	Make sure hoses are connected to correct faucets.
	House water heater is not set properly	Make sure house water heater is delivering water at 120°–140°F (48°–60°C). (HOT to HOT and COLD to COLD).
Bad odor inside your Washer	Washer unused for a long time, not using recommended quality of HE detergent or used too much detergent	Regularly use ULTRAFRESH VENT between uses.
		In case of strong odor, you may need to run the Self Clean cycle more than once.
		Use only the amount of detergent recommended or adjust SmartDispense to LOW .
		Use only HE (high efficiency) detergent.
		Always remove wet items from the washer promptly after it stops running or use 1 Step Wash + Dry or Tumble Care .
		If you choose to not use the ULTRAFRESH VENT System, leave the door slightly open for the washer to air dry. Close supervision is necessary if this appliance is used by or near children. Do not allow children to play on or in this appliance.
	There is residual lint, etc. in the drain pump filter which should be cleaned	See the Care and Cleaning section on how to clean the Pump Filter .
Drain hose pushed too far down the drain	See the Installation Instructions section for proper installation.	
Detergent begins to slowly dispense into tub	This is normal	It is normal operation to see detergent leak on door gasket about 20 seconds after filling the dispenser.
Improper dispensing of softener or bleach	Dispenser clogged	Monthly clean the dispenser drawer to remove buildup of chemicals.
	Softener or bleach is filled above the max line	Make sure to have the correct amount of softener.
Dispenser drawer not dispensing properly	Laundry detergent packet placed in dispenser drawer	Laundry detergent packets should not be used in the dispenser. They should only be added directly to the wash basket following the manufacturer's directions.
Pump running while washer is not in use	Clog in sump drain	This is normal. Drain sump is detecting an undesired water fill level from a potential open faucet. Shut off water valve and inspect water valve for blockage. Ensure you have the latest updates for your washer available through the SmartHQ App.

GE Appliances Washer Limited Warranty

LIMITED WARRANTY

GEAppliances.com

All warranty service is provided by our Factory Service Centers, or an authorized Customer Care® technician. To schedule service online, visit us at GEAppliances.com/service, or call GE Appliances at 800.GE.CARES (800.432.2737). Please have your serial number and your model number available when calling for service.

Servicing your appliance may require the use of the onboard data port for diagnostics. This gives a GE Appliances factory service technician the ability to quickly diagnose any issues with your appliance and helps GE Appliances improve its products by providing GE Appliances with information on your appliance. If you do not want your appliance data to be sent to GE Appliances, please advise your technician not to submit the data to GE Appliances at the time of service.

For the period of:	We will replace:
One year From the date of the original purchase	Any part of the washer which fails due to a defect in materials or workmanship. During this limited one-year warranty , we will also provide, free of charge , all labor and related service to replace the defective part.
Ten years From the date of the original purchase	The motor , if it should fail due to a defect in materials or workmanship. During this additional nine-year limited warranty , you will be responsible for any labor and related service costs.

What is not covered:

- Service trips to your home to teach you how to use the product.
- Improper installation, delivery or maintenance.
- Failure of the product if it is abused, misused, or used for other than the intended purpose or used commercially.
- Replacement of house fuses or resetting of circuit breakers.
- Products which are not defective or broken, or which are working as described in the Owner's Manual.
- Damage to the product caused by accident, fire, floods or acts of God.
- Incidental or consequential damage caused by possible defects with this appliance.
- Defects or damage due to operation in freezing temperatures.
- Damage caused after delivery.
- Product not accessible to provide required service.

EXCLUSION OF IMPLIED WARRANTIES

Your sole and exclusive remedy is product repair as provided in this Limited Warranty. Any implied warranties, including the implied warranties of merchantability or fitness for a particular purpose, are limited to one year or the shortest period allowed by law.

In the United States:

This limited warranty is extended to the original purchaser and any succeeding owner for products purchased for home use within the USA. If the product is located in an area where service by a GE Appliances Authorized Servicer is not available, you may be responsible for a trip charge or you may be required to bring the product to an Authorized GE Appliances Service location for service. In Alaska, the limited warranty excludes the cost of shipping or service calls to your home.

Some states do not allow the exclusion or limitation of incidental or consequential damages. This limited warranty gives you specific legal rights, and you may also have other rights which vary from state to state. To know what your legal rights are, consult your local or state consumer affairs office or your state's Attorney General.

Warrantor: GE Appliances, a Haier Company, Louisville, KY 40225

In Canada:

This limited warranty is extended to the original purchaser and any succeeding owner for products purchased in Canada for home use within Canada. If the product is located in an area where service by a GE Appliances Authorized Servicer is not available, you may be responsible for a trip charge or you may be required to bring the product to an Authorized GE Appliances Service location.

Some provinces do not allow the exclusion or limitation of incidental or consequential damages. This limited warranty gives you specific legal rights, and you may also have other rights which vary from province to province. To know what your legal rights are, consult your local or provincial consumer affairs office.

Warrantor: MC Commercial Inc., Burlington, ON, L7R 5B6

Extended Warranties: Purchase a GE Appliances extended warranty and learn about special discounts that are available while your warranty is still in effect. You can purchase it online anytime at

GEAppliances.com/extended-warranty

or call 800.626.2224 during normal business hours. GE Appliances Service will still be there after your warranty expires.

Staple your receipt here. Proof of the original purchase date is needed to obtain service under the warranty.

Consumer Support

GE Appliances Website

Have a question or need assistance with your appliance? Try the GE Appliances Website 24 hours a day, any day of the year! You can also shop for more great GE Appliances products and take advantage of all our on-line support services designed for your convenience. In the US: **GEAppliances.com**

In Canada: **GEAppliances.ca**

Register Your Appliance

Register your new appliance on-line at your convenience! Timely product registration will allow for enhanced communication and prompt service under the terms of your warranty, should the need arise. You may also mail in the pre-printed registration card included in the packing material. In the US: **GEAppliances.com/register**

In Canada: **GEAppliances.ca/after-sales-support**

Schedule Service

Expert GE Appliances repair service is only one step away from your door. Get on-line and schedule your service at your convenience any day of the year. In the US: **GEAppliances.com/service** or call 800.432.2737 during normal business hours.

In Canada: **GEAppliances.ca/after-sales-support** or call 800.561.3344.

Extended Warranties

Purchase a GE Appliances extended warranty and learn about special discounts that are available while your warranty is still in effect. You can purchase it on-line anytime. GE Appliances Services will still be there after your warranty expires. In the US: **GEAppliances.com/extended-warranty** or call 800.626.2224 during normal business hours.

In Canada: **GEAppliances.ca/purchase-extended-warranty** or call 866.277.9842.

Remote Connectivity

For assistance with wireless network connectivity (for models with remote enable), in the US visit our website at **GEAppliances.com/connect** or call 800.220.6899.

In Canada: **GEAppliances.ca/connected-appliances** or call 800.220.6899

Parts and Accessories

Individuals qualified to service their own appliances can have parts or accessories sent directly to their homes (VISA, MasterCard and Discover cards are accepted). Order on-line today 24 hours every day.

In the US: **GEApplianceparts.com** or by phone at 877.959.8688 during normal business hours.

In Canada: **GEAppliances.ca/parts-filters-accessories** or call 800.661.1616.

Instructions contained in this manual cover procedures to be performed by any user. Other servicing generally should be referred to qualified service personnel. Caution must be exercised, since improper servicing may cause unsafe operation.

Contact Us

If you are not satisfied with the service you receive from GE Appliances, contact us on our Website with all the details including your phone number, or write to:

In the US: General Manager, Customer Relations | GE Appliances, Appliance Park | Louisville, KY 40225
GEAppliances.com/contact or call 800.626.2000

In Canada: Director, Customer Relations | MC Commercial Inc. | Suite 300, 5420 North Service Road | Burlington, ON L7L 6C7
GEAppliances.ca/contact-us or call 877.994.5366

QUICK REFERENCE GUIDE

Getting started







Step 1
Load clothes into your washer and close the door.

Step 2
Turn the knob to wake up the display and select your desired cycle.

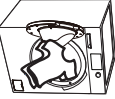
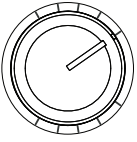
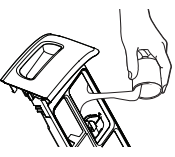
Step 3
Open the dispenser to add detergent, or on models with SmartDispense™, select the SmartDispense setting as desired.

Step 4
Press Start to begin the wash cycle. When finished, the door will unlock.

Step 5
For washers equipped with the UltraFresh Vent™, select this option to eliminate excess moisture when you're done with laundry for awhile. Otherwise, leave your washer door slightly ajar.

Try these washer features (not available on all models)

UltraFresh Vent™
Works to eliminate excess moisture to help prevent odors so your washer stays fresh and clean.

OdorBlock™
Microban® technology delivers antimicrobial durable protection that lives on load after load.







SmartDispense™
The dispenser holds up to 32 loads and automatically dispenses the right amount every time. Use only HE High-Efficiency detergent.

1 Step Wash + Dry
Wash and dry a small load to eliminate the need to transfer clothes to the dryer.

Time Saver
Delivers a thorough clean for any size and type of load in only 35 minutes.

WiFi SMART
Monitor and control your laundry from anywhere and receive real-time updates and notifications.

dB™ QUIET CONTROL
Onboard sensing enables real-time balancing during spin to save time and reduce noise.

Troubleshooting Tips... Before you call for service
Before you call for service, see the Troubleshooting Tips section in your **OWNER'S MANUAL & INSTALLATION INSTRUCTIONS.**

Service

If needed, schedule a visit from GE Appliances local factory service for advanced service by visiting localgeappliancerepair.com or calling 866.530.7025.

GE is a trademark of the General Electric Company. Manufactured under trademark license.

Care & Cleaning

Cleaning the pump filter

Step 1: Open the access door using a coin or flat screwdriver in the notch of the door and pull down the pour spout.

Step 2: Place a shallow pan or dish under the pump access door and towels on the floor for protection. It is normal for up to a cup of water to drain from the filter.

Step 3: Turn pump filter counterclockwise and remove the filter slowly to let the water drain.

Step 4: Clean the debris from the filter.

Step 5: Replace the filter by pushing in firmly and turning clockwise until tightened securely. Flip up the pour spout and close the access door.

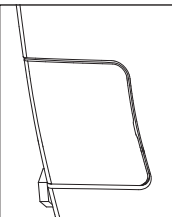
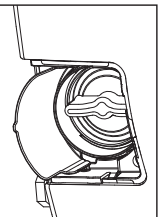
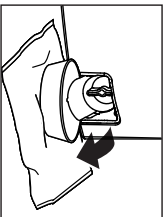
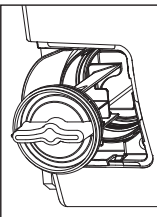
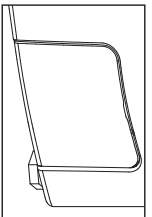
NOTE: Clean pump filter every 6 months or sooner if unit is not draining properly.

Video



Scan this code to watch a video on this topic.

Cleaning the interior of the washer

To clean the interior of the washer, use the **SELF CLEAN** cycle using the following procedure:

Step 1: Remove any garments or objects from the washer to ensure the basket is empty.

Step 2: Open the door and add one cup (250 ml) of bleach directly into the washer basket.

Step 3: Close the door and select the **SELF CLEAN** cycle. Press the **Start** pad.

Step 4: When the **SELF CLEAN** cycle is working, the display will show the estimated cycle time remaining. The cycle will complete in about 90 minutes. Do not interrupt the cycle.

IMPORTANT

- Run **SELF CLEAN** with tub cleaner once a month.
- After the completion of a **SELF CLEAN** cycle, the interior of your washer may have a bleach smell.
- It is recommended to run a **RINSE & SPIN** or a light color load after the **SELF CLEAN** cycle.

Step 5: After the cycle is complete (on some models), the washer will automatically start an **UltraFresh Vent** operation so that the door can remain closed until the next time the washer is used. **SELF CLEAN** may be interrupted by pressing **Start/Pause**. When interrupted, be sure to run a complete **SELF CLEAN** cycle before using the washer again. For more information, please refer to your **OWNER'S MANUAL**.



Cleaning the door gasket

STEP 1: Open the washer door.

STEP 2: Press down on the door gasket and pull down on the interior gasket with your fingers.

STEP 3: Remove any foreign objects trapped inside the interior gasket.

STEP 4: When you are finished cleaning the door gasket, release it and the gasket will return to the operating position.

NOTE: Make sure nothing is blocking holes behind gasket.



Routine maintenance

Genuine GE Appliances Parts and Accessories make appliance maintenance easy by providing cleaning products, replacement parts and accessories that are designed to keep your appliance at peak performance. To order direct visit GEApplianceparts.com or call 877.959.8688.



GE APPLIANCES

QUICK INSTALLATION GUIDE



DO NOT DISCARD
KEEP FOR FUTURE USE

⚠ WARNING

For your safety

- To reduce the risk of fire, electric shock, or injury to persons, read the **IMPORTANT SAFETY INFORMATION** before operating this appliance.
- Do not install or store appliance in an area where it will be exposed to dripping water or outside weather conditions. See Location of Your Washer section.
- NOTE:** This appliance must be properly grounded and installed as described in this manual. Electrical service to the washer must conform with local codes and ordinances and the latest edition of the national Electrical Code, ANSI/NFPA 70.

1 Unpack your washer

PARTS SUPPLIED

- Cable tie
- Hose guide
- 4 Shipping bolt covers
- Lock Bar (For Reversing the Door Swing)

TOOLS NEEDED

- Adjustable wrench
- Channel-lock pliers
- Phillips Screwdriver
- Level

PARTS REQUIRED

- (Sold separately or included with the GFW510 model)
- Water Hoses with 90° elbows (2)
 - Rubber washers (2) and strainer screens

2 Remove shipping hardware

- Once the washer is within 4 feet of its destination, use a 1/2" wrench or socket to remove the following from the back side:
- 4 shipping bolts
 - 4 plastic spacers (including power cord retainers and rubber grommets)
 - 1 bracket
- Insert the hole caps in the bolt holes once the shipping bolts and spacers have been removed. Save all shipping support hardware for future use. Recycle or destroy the carton after the washer is unpacked.

Video

Scan this code to watch a video on Step 2.

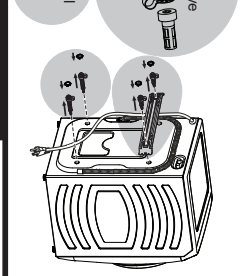
3 Connect hoses to washer

- Run water from both faucets to flush the lines and remove particles that might clog the water valve screens.
- Ensure that a rubber washer is in the end of the hot and cold hoses.
- Connect the inlet hoses to the hot "H" outlet and cold "C" outlet.
- Hand-tighten and then tighten them another 2/3 turn with pliers. Do not cross-thread or over-tighten these connections.

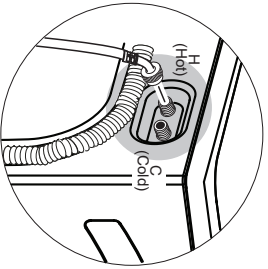

GE Appliances recommends inlet hoses that have a 90° bend at one end. The 90° bend should be installed at the washer as shown above.

4 Connect hoses to water supply

- Ensure that a screen washer is inserted into the faucet end of both hoses with protruded side facing the faucet. If a rubber washer is already inserted, remove before inserting screen washer.
- Connect the inlet hose from the "H" outlet to the hot faucet and the inlet hose from the "C" outlet to the cold faucet.
- Hand-tighten and then tighten them another 2/3 turn with pliers.
- Turn on the water and check for leaks.

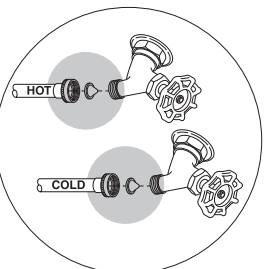

5 Level your washer

- Gently rock the washer into final location, ensuring inlet hoses do not become kinked. Do not use door or dispenser drawer to lift the washer.
- Place level on top.
- Adjust the front leveling legs up or down to ensure the washer is resting solidly.
- Turn the lock nuts on each leg up toward the base of the washer and snug with a wrench.
- Level washer both side-to-side and front-to-back.

Video

Scan this code to watch a video on Step 5.

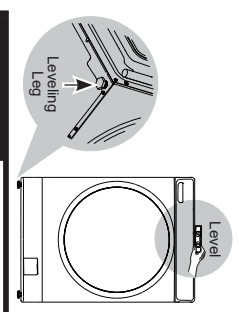
6 Install drain hose and plug

- Attach U-shaped hose guide to end of drain hose.
- Place hose in laundry tub or standpipe and secure with cable tie.
- If placed in standpipe, the end of the drain hose should extend only 4 to 7 inches down the pipe.
- If you desire to reverse the door, perform step 7 now.
- Plug washer into a grounded outlet. Do not use an extension cord or adaptor plug.

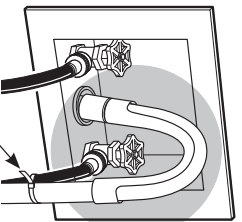

7 Optional: Reverse the washer door

- While supporting the open door, remove the screws from the hinge.
- Remove the door hinge and cover.
- Remove the door striker assembly, reverse the striker and replace the assembly on the opposite side.
- Replace the door hinge and cover on the opposite side.
- Remove the terminal holder and disconnect the pin connector.
- Remove lock assembly and install on opposite side.
- Reconnect pin connector and replace the holder.
- Replace the door assembly.

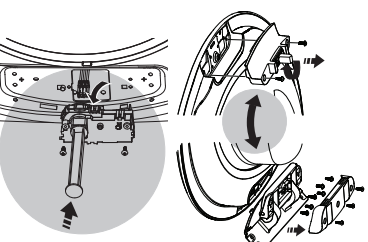

8 Final installation checklist

- Main power is turned on. The washer is plugged in.
- Faucets are turned on. Water hoses are connected securely with no leaks at both ends.
- Unit is level and all legs are on the floor.
- Shipping bolts and spacers are removed and stored for future use.
- Drain hose is placed in tub or standpipe and secured with a cable tie.
- Run a load of clothes using the **Quick Wash** cycle. Check for leaks.
- When the load is spinning at high speed, ensure that the washer and leveling legs are stable.