



Bottom Freezer REFRIGERATORS

SAFETY INFORMATION 3

OPERATING INSTRUCTIONS

Features..... 6
 Controls 9
 Dispenser* 13
 Autofill* 14
 Single Serve Brewer*..... 15
 About Appliance Communication... 16
 Water Filter..... 17
 Refrigerator Storage Options..... 18
 Climate Zone & Temperature
 Controlled Drawer 20
 Freezer..... 22
 Automatic Ice maker 23

CARE AND CLEANING 24

Replacing the Lights 25

INSTALLATION INSTRUCTIONS

Preparing to Install the
 Refrigerator..... 26
 Installing the Refrigerator..... 28
 Installing the Water Line..... 42

TROUBLESHOOTING TIPS.. 46

Normal Operating Conditions 45
 Truth or Myth 49

LIMITED WARRANTY 51

CONSUMER SUPPORT

RPWFE Water Filter Cartridge
 Limited Warranty..... 52
 Performance Data Sheet..... 53
 Consumer Support..... 54

*Select Models Only

Write the model and serial numbers here:

Model # _____

Serial # _____

Find these numbers on a label on the left side, near the middle of the refrigerator compartment.

OWNER'S MANUAL & INSTALLATION INSTRUCTIONS

GE Profile™ Models

Models that start with DFE, GFE, GFS, GNE, PFH, PFE, PFD and GFD are Standard Depth Models (SD)

Models that start with GYE, GYS, GWE, PYE, DYE, PWE, ZWE and PYD are Counter Depth Models (CD)

ENGLISH/FRANÇAIS/ESPAÑOL

THANK YOU FOR MAKING GE APPLIANCES A PART OF YOUR HOME.

Whether you grew up with GE Appliances, or this is your first, we're happy to have you in the family.

We take pride in the craftsmanship, innovation and design that goes into every GE Appliances product, and we think you will too. Among other things, registration of your appliance ensures that we can deliver important product information and warranty details when you need them.

Register your GE appliance now online. Helpful websites and phone numbers are available in the Consumer Support section of this Owner's Manual. You may also mail in the pre-printed registration card included in the packing material.



GE APPLIANCES

IMPORTANT SAFETY INFORMATION

READ ALL INSTRUCTIONS BEFORE USING THE APPLIANCE

▲ WARNING To reduce the risk of fire, explosion, electric shock, or injury when using your refrigerator, follow these basic safety precautions:

- This refrigerator must be properly installed and located in accordance with the Installation Instructions before it is used.
- Unplug the refrigerator before making repairs, replacing a light bulb, or cleaning.
NOTE: Power to the refrigerator cannot be disconnected by any setting on the control panel.
NOTE: Repairs must be performed by a qualified Service Professional.
- Replace all parts and panels before operating.
- Do not use an extension cord.
- Do not store or use gasoline or other flammable vapors and liquids in the vicinity of this or any other appliance.
- Do not store explosive substances such as aerosol cans with a flammable propellant in this appliance.
- To prevent suffocation and entrapment hazards to children, remove the refrigerator and freezer doors from any refrigerator before disposing of it or discontinuing its use.
- To avoid serious injury or death, children should not stand on, or play in or with the appliance.
- Children and persons with reduced physical, sensory or mental capabilities or lack of experience and knowledge can use this appliance only if they are supervised or have been given instructions on safe use and understand the hazards involved.
- This appliance is intended to be used in household and similar applications such as: staff kitchen areas in shops, offices and other working environments; farm houses; by clients in hotels, motels, bed & breakfast and other residential environments; catering and similar non-retail applications.
- Do not apply harsh cleaners to the refrigerator. Certain cleaners will damage plastic which may cause parts such as the door or door handles to detach unexpectedly. See the Care and Cleaning section for detailed instructions.
- Connect to potable water supply only with water pressure maximum of 120 psi (827 kilopascals).

▲ CAUTION To reduce the risk of injury when using your refrigerator, follow these basic safety precautions.

- Do not clean glass shelves or covers with warm water when they are cold. Glass shelves and covers may break if exposed to sudden temperature changes or impact, such as bumping or dropping. Tempered glass is designed to shatter into many small pieces if it breaks.
- Keep fingers out of the “pinch point” areas; clearances between the doors and between the doors and cabinet are necessarily small. Be careful closing doors when children are in the area.
- Do not touch the cold surfaces in the freezer compartment when hands are damp or wet, skin may stick to these extremely cold surfaces.
- Do not refreeze frozen foods which have thawed completely.
- In refrigerators with automatic icemakers, avoid contact with the moving parts of the ejector mechanism, or with the heating element that releases the cubes. Do not place fingers or hands on the automatic ice making mechanism while the refrigerator is plugged in.

INSTALLATION

▲ WARNING FIRE OR EXPLOSION HAZARD

Keep flammable materials and vapors away from refrigerator. Failure to do so can result in fire, explosion, or death.

▲ WARNING  TIP OVER HAZARD.

If an anti-tip floor bracket was included with your refrigerator, install it to prevent the refrigerator from tipping forward, which could result in death or serious injury. Read and follow the entire installation instructions for installing the anti-tip floor bracket packed with your refrigerator.

READ AND SAVE THESE INSTRUCTIONS

IMPORTANT SAFETY INFORMATION

READ ALL INSTRUCTIONS BEFORE USING THE APPLIANCE

CONNECTING ELECTRICITY

⚠ WARNING **ELECTRICAL SHOCK HAZARD**

Plug into a grounded 3-prong outlet
 Do not remove the ground prong
 Do not use an adapter
 Do not use an extension cord.
 Failure to follow these instructions can result in death, fire, or electrical shock.

Do not, under any circumstances, cut or remove the third (ground) prong from the power cord. For personal safety, this appliance must be properly grounded.

The power cord of this appliance is equipped with a 3-prong (grounding) plug which mates with a standard 3-prong (grounding) wall outlet to minimize the possibility of electric shock hazard from this appliance.

Have the wall outlet and circuit checked by a qualified electrician to make sure the outlet is properly grounded.

Where a standard 2-prong wall outlet is encountered, it is your personal responsibility and obligation to have it replaced with a properly grounded 3-prong wall outlet. Do not use an adapter.

The refrigerator should always be plugged into its own individual electrical outlet which has a voltage rating that matches the rating plate.

A 115 Volt AC, 60 Hz, 15- or 20-amp fused, grounded electrical supply is required. This provides the best performance and also prevents overloading house wiring circuits which could cause a fire hazard from overheated wires.

Never unplug your refrigerator by pulling on the power cord. Always grip plug firmly and pull straight out from the outlet.

Immediately discontinue use of a damaged supply cord. If the supply cord is damaged, it must be replaced by a qualified service professional with an authorized service part from the manufacturer.

When moving the refrigerator away from the wall, be careful not to roll over or damage the power cord.

PROPER DISPOSAL OF YOUR OLD REFRIGERATOR

⚠ WARNING **SUFFOCATION AND ENTRAPMENT HAZARD**

Failure to follow these disposal instructions can result in death or serious injury

IMPORTANT: Child entrapment and suffocation are not problems of the past. Junked or abandoned refrigerators are still dangerous even if they will sit for “just a few days.” If you are getting rid of your old refrigerator, please follow the instructions below to help prevent accidents.

Before You Throw Away Your Old Appliance

- Take off the refrigerator and freezer doors.
- Leave the shelves in place so that children may not easily climb inside.

REFRIGERANT AND FOAM DISPOSAL:

Dispose of or recycle appliance in accordance with Federal and Local Regulations. Flammable refrigerant and insulation material used requires special disposal procedures. Contact your local authorities for the environmentally safe disposal or recycling of your appliance.

READ AND SAVE THESE INSTRUCTIONS

IMPORTANT SAFETY INFORMATION

READ ALL INSTRUCTIONS BEFORE USING THE APPLIANCE

HOT WATER DISPENSER

▲ WARNING



Scalding Hazard.

The hot water dispenser is capable of heating water to a temperature of approximately 185°F (85°C). Water temperatures above 125°F (52°C) can cause severe burns or death from scalding. Children, the disabled, and the elderly are at highest risk of being scalded.

Use this appliance only for its intended purpose as described in this Owner's Manual. To reduce the risk of severe burns, scald injuries, or death when using your hot water dispenser, the instructions below must be followed:

- Do not leave container unattended around children during or after hot water dispense.
- Do not permit children to use the hot water dispenser.
- The hot water dispensing knob requires both twist and push motions in order to reduce the risk of hot water being dispensed unintentionally or by small children. Do not tamper with or modify the hot water dispensing knob.
- The water coming from the dispenser is very hot. Use extreme caution when dispensing and drinking water. Allow water to cool to a drinkable temperature before drinking. Your container should be close to the dispensing point to minimize the splashing of hot water.
- When dispensing hot water, the container can become very hot. Use a temperature insulating container, such as ceramic or foam. Using container materials such as paper or plastic may result in a burn while holding the cup. Do not use glass containers, as thermal shock can cause the container to break and may result in scalding or lacerations.
- Always follow the formula manufacturer's instructions for preparation of baby formula. When dispensing water below 125°F (51.67 cm), always test the temperature of the water before drinking.
- The first time the hot water feature is used, confirm if you live above 5000 feet (1524 meters) (high altitude). This limits the temperature of the hot water system to avoid boiling. To access the high altitude selection, go to the settings menu if available or for other models press **Fridge** and **Door Alarm** together to cycle from **Hi AL** to **Lo AL** (high altitude to low altitude).
- A newly installed water filter cartridge will cause water to spurt from the dispenser. Run 2 gallons (7.57 liters) of water through the cold water dispenser (about 5 minutes) to remove air from the system. Until this air is removed from the system through the cold water dispenser, **DO NOT** use the hot water dispenser as it may result in spurting of hot water and lead to hot water scalding.
- Do not use with water that is microbiologically unsafe or of unknown quality.
- The hot water dispenser is designed to only dispense water. Do not attempt to heat or dispense anything other than water. Do not attempt to disassemble or clean the tank.
- Do not modify the hot water system. Service with factory replacement part only.

Check the rating label for refrigerant type. If R600a, follow the warning instructions below.

▲ WARNING



FIRE OR EXPLOSION HAZARD Flammable Refrigerant

This appliance contains isobutane refrigerant, also known as R600a, a natural gas with high environmental compatibility. However, it is also combustible. Adhere to the warnings below to reduce the risk of injury or property damage.

1. When handling, installing and operating the appliance, care should be taken to avoid damage to the refrigerant tubing.
2. Service shall only be performed by authorized service personnel. Use only manufacturer-authorized service parts.
3. Dispose of refrigerator in accordance with the Federal and Local Regulations. The flammable refrigerant and insulation material used in this product require special disposal procedures. Contact your local authorities for the environmentally safe disposal of your refrigerator.
4. Keep ventilation openings in the appliance enclosures or in the built-in structure clear of obstruction.
5. To remove frost, scrape with a plastic or wood spatula or scraper. Do not use an ice pick or a metal or sharp-edged instrument as it may puncture the freezer liner and then the flammable refrigerant tubing behind it.
6. Do not use electrical appliances inside the food storage compartment of the appliance.
7. Do not use any electrical device to defrost your freezer.

Features

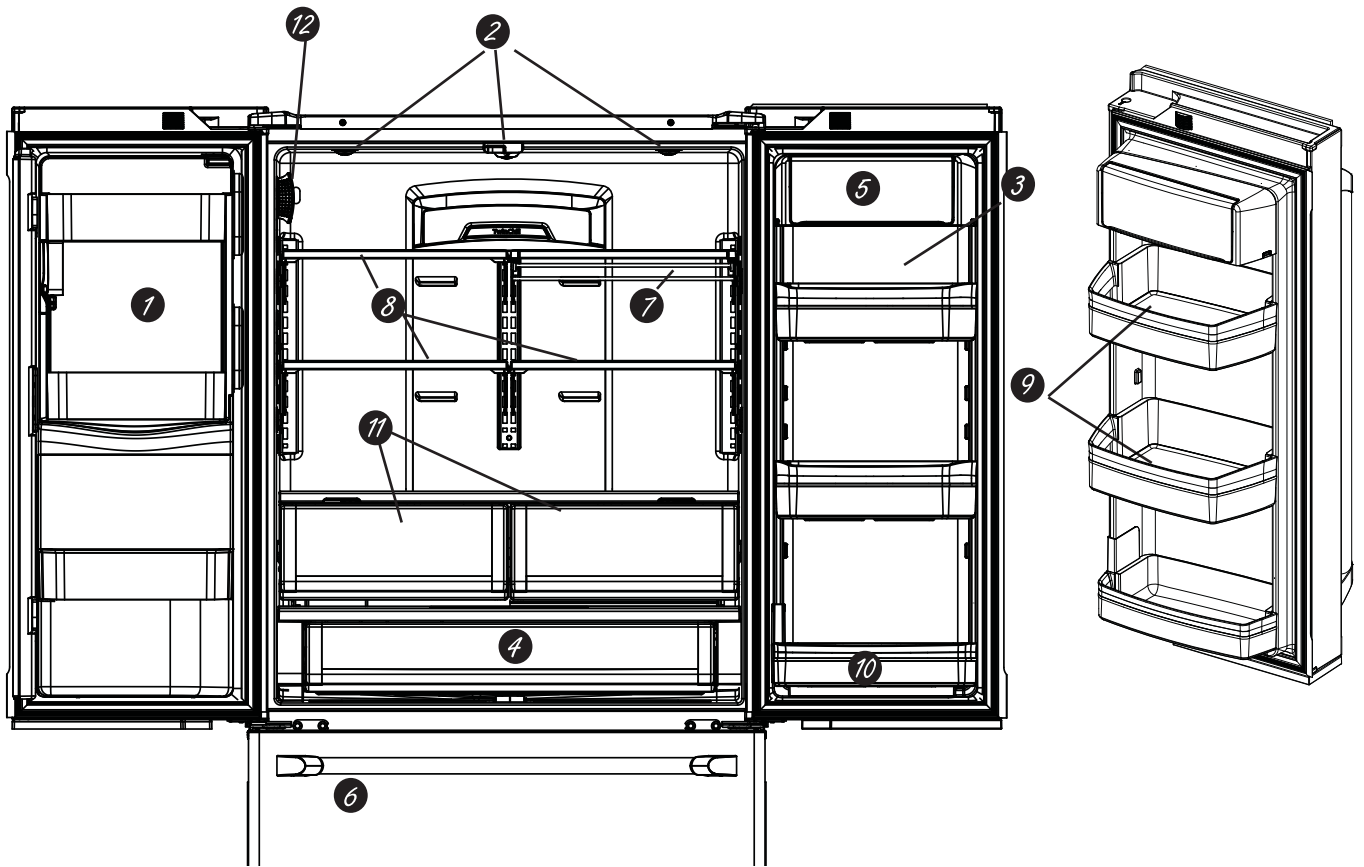

- 1 Space-saving ice maker***
Ice maker and bin are located on the door creating more usable storage space.
- 2 Showcase LED lighting**
LED lighting is positioned throughout the interior to spotlight areas in the refrigerator. LEDs are located under the refrigerator door to light the freezer when opened.
- 3 Drop-down tray***
Allows for extra door storage when you need it and tucks away when you don't.
- 4 Full-width temperature controlled drawer**
Adjustable temperature control bin that can accommodate larger items.
- 5 Dairy bin***
Separate compartment for your items.
- 6 Ice bin/Ice maker***
Ice maker with ice storage bins.
- 7 QuickSpace™ shelf***
Functions as a normal full-sized shelf when needed and easily slides back to store tall items below.
- 8 Spillproof shelves**
Designed to capture your spills for easier clean up.
- 9 Anti-slip Mat***
Liner that captures spills, keeps containers from shifting when the door is opened and is easily removable for cleaning.
- 10 Removable door bin**
Can be removed for those with a wall limiting the door opening.
- 11 Climate zone bin**
Separate bins for produce storage.
- 12 Water filter**
Filters water and ice.

* Select models only.

Features

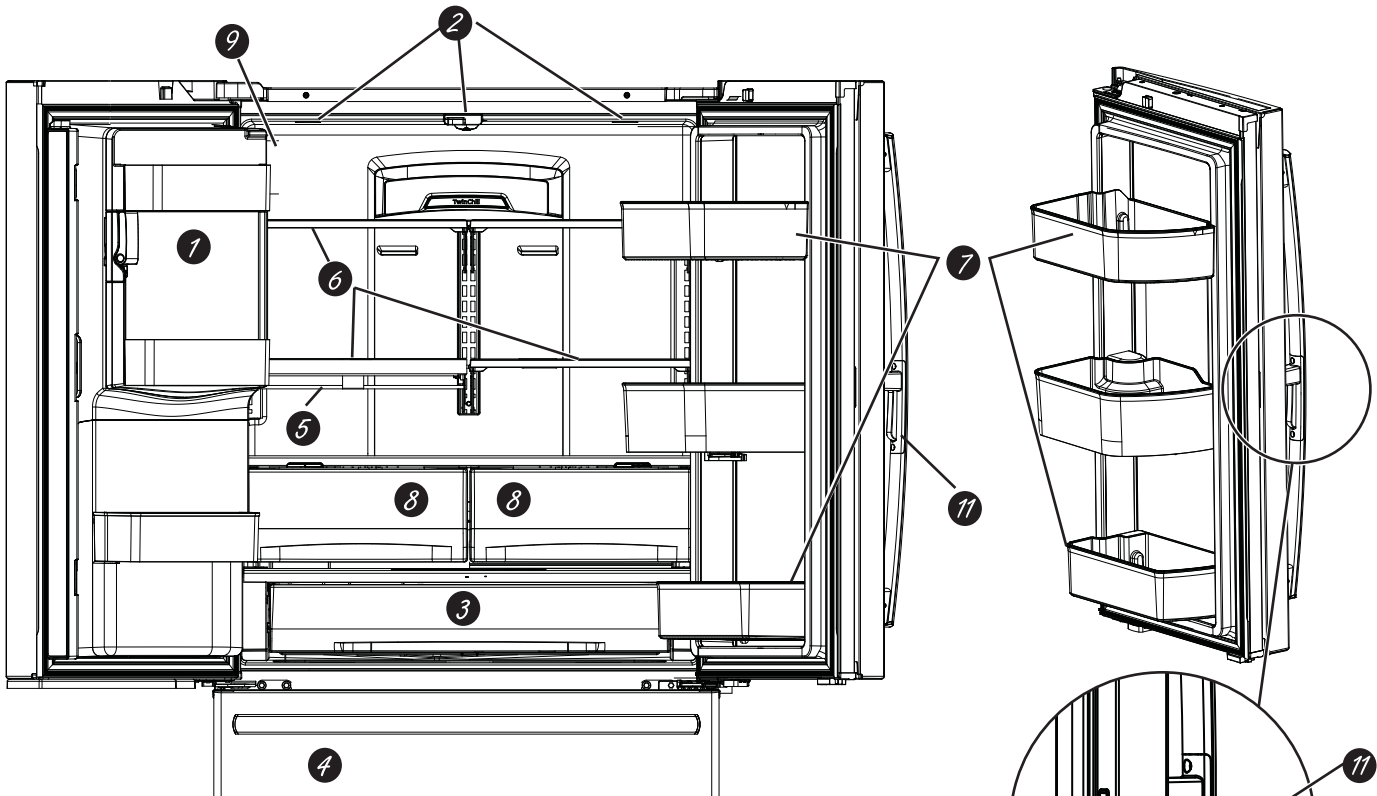

- 1 Space-saving ice maker***
Ice maker and bin are located on the door creating more usable storage space.
- 2 Showcase LED lighting**
LED lighting is positioned throughout the interior to spotlight areas in the refrigerator. LEDs are located under the refrigerator door to light the freezer when opened.
- 3 Full-width temperature controlled drawer**
Adjustable temperature control bin that can accommodate larger items.
- 4 Freezer Ice maker/Ice Bin***
An ice maker in both compartments give you more ice whenever you need it. Available on Non-Dispense models, also available as a kit for some models.
- 5 QuickSpace™ shelf***
Functions as a normal full-sized shelf when needed and easily slides back to store tall items below.
- 6 Spillproof shelves**
Designed to capture your spills for easier clean up.
- 7 Removable door bin**
Can be removed for those with a wall limiting the door opening.
- 8 Climate zone bin**
Separate bins for produce storage.
- 9 Water filter**
Filters water and ice.
- 10 Rotating Bin***
Can be rotated out for easy access.
- 11 Door in Door Latch***
Squeeze the latch on the underside of the handle to open the outer door.

* Select models only.

Features

1 Door ice bin*

1. Open left refrigerator door.
2. Pull down latch to release bin door.
3. Using handhold lift ice bucket up and out to clear locators in bottom of bin.
4. To replace the ice bucket, set it on the guide brackets and push until the ice bucket seats properly.
5. If bucket cannot be replaced, rotate the Ice Bucket Fork 1/4 turn clockwise.

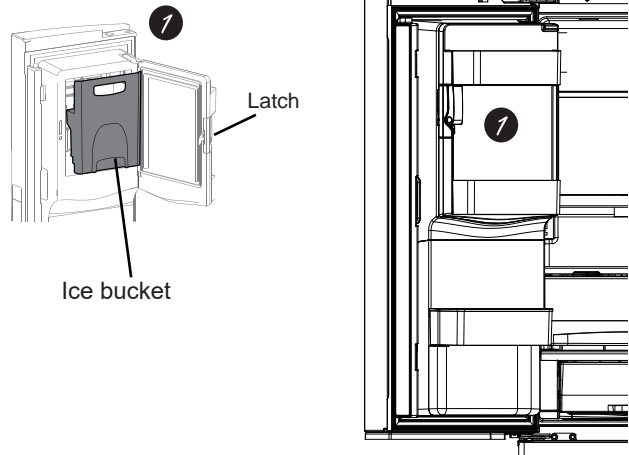

2 Ice/water filter

Certified to reduce chlorine-resistant cysts, lead, select pharmaceuticals, and more. For easy filter replacement instructions see page 17.

⚠ WARNING  **Scalding Hazard.***

Use of the hot water dispenser prior to purging air from the system may result in spurting of hot water and lead to hot water scalding. Follow the instructions for “Water Filter - Step 3” on page 17 to purge all air from the system through the cold water dispenser prior to using the hot water dispenser.

The first time the hot water feature is used, confirm if you live above 5000 feet (1524 meters) (high altitude). This limits the temperature of the hot water system to avoid boiling. To access the high altitude selection, see Controls.

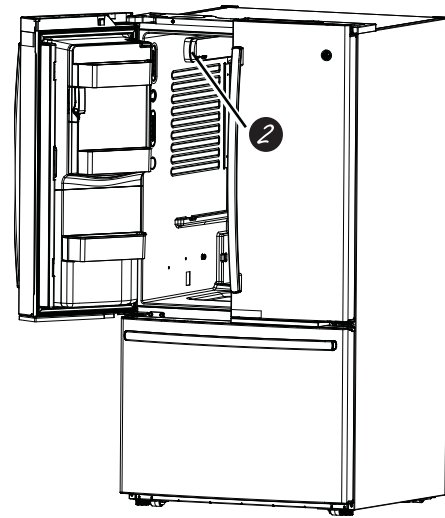

*Select Models Only

Controls

PFE28P, PYE22P Control Style A, Single Serve Models

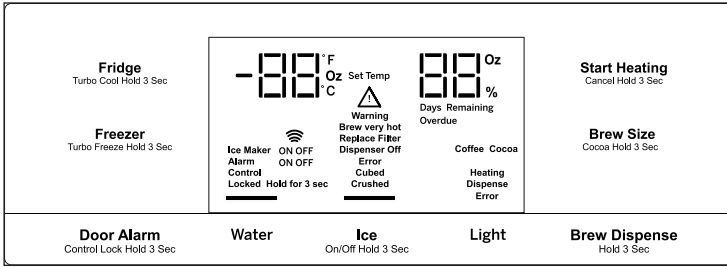

PFH28, PFE28K, DFE28, PFD28, PYE22K, PYD22, DYE22 Control Style B, AutoFill Models

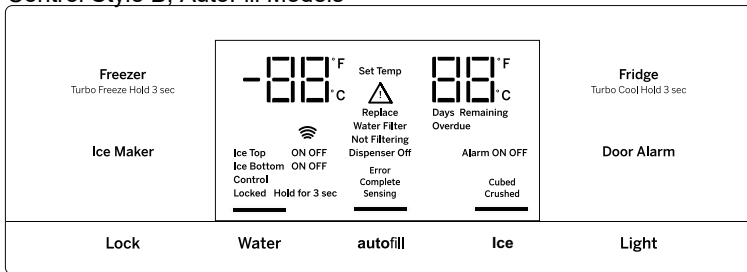

GFD28, GFE28, GFE26, GFS26, GYS22, GYE22 Control Style C, GE Models

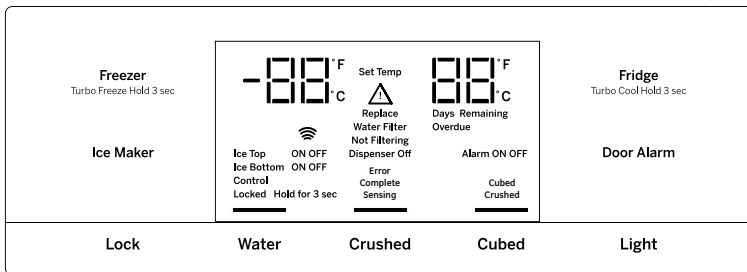

GNE29, GWE23, PWE23 Control Style D, Non-Dispense Control

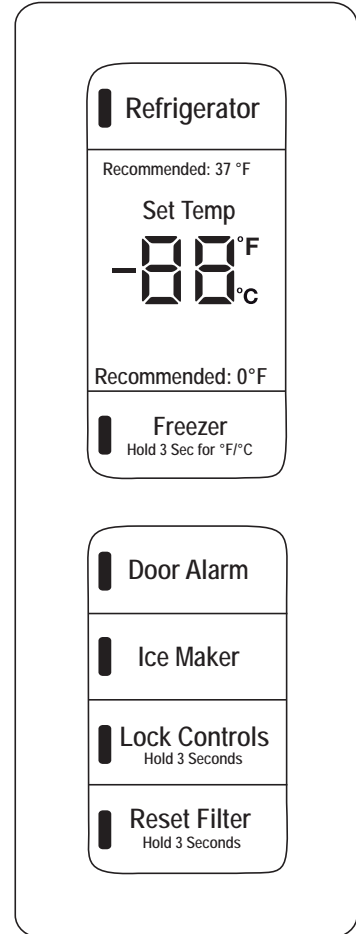

NOTE: The refrigerator is shipped with protective film covering the temperature controls. If this film was not removed during installation, remove it now.

The temperature controls are preset in the factory at 37°F for the refrigerator compartment and 0°F for the freezer compartment. Allow 24 hours for the temperature to stabilize to the preset recommended settings.

Control Style D: The temperature controls display the set temperature.

Controls

Changing the Temperature for Control Style A

To Change the Refrigerator Temperature:

Press the **Fridge** button and current set temperature will display. Pressing and releasing the button will cycle through the available temperature settings. Press and hold button for **Turbo Cool** feature. The display will show **tC**.

To Change the Freezer Temperature:

Press the **Freezer** button and current set temperature will display. Pressing and releasing the button will cycle through the available temperature settings. Press and hold button for **Turbo Freeze** feature. The display will show **tF**.

Cooling system can be turned off by pressing and holding **Freezer** and **Start Heating**. **OFF** will be displayed. To turn on, press **Fridge** or **Freezer**. **ON** will be displayed.

Turning the cooling system off stops the cooling to the refrigerator, but it does not shut off the electrical power.

Changing the Temperature for Control Styles B and C

To change the temperature, press and release the **Freezer** or **Fridge** pad. The display will show the set temperature. To change the temperature, press either the **Freezer** or **Fridge** pad until the desired temperature is displayed. Press and hold button for **Turbo Cool** feature. The display will show **tC**. Press and hold button for **Turbo Freeze** feature. The display will show **tF**.

To turn off the cooling system press and hold the **Fridge** and **Ice Maker** buttons. To turn on, press **Fridge** or **Freezer**.

Turning the cooling system off stops the cooling to the refrigerator, but it does not shut off the electrical power.

Changing Temp. for Control Style D

Temperature Display is located on inside of left-hand refrigerator door. To change the temperature, press and release the **REFRIGERATOR** or **FREEZER** pad. To change the temperature, tap either the **REFRIGERATOR** or **FREEZER** pad until the desired temperature is displayed.

To turn **OFF** cooling system, press and hold the **REFRIGERATOR** and **FREEZER** pads simultaneously for 3 seconds. When cooling system is **OFF** the display should read **OF**. To turn **ON** cooling system, press either **REFRIGERATOR** or **FREEZER** pad. The display will show the preset temperature settings of **37°F (3°C)** for refrigerator and **0°F (-18°C)** for freezer.

Turning the cooling system off stops the cooling to refrigerator, but it does not shut off the electrical power.

NOTE: For optimal temperature performance, we recommend to avoid placing food items directly at the air flow vents of the refrigerator air tower and thus blocking the air flow.

Controls

Control Style A, External Controls PFE28P, PYE22P

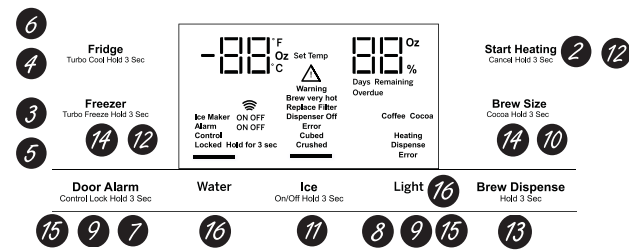

Control Style B, External Controls PFH28, PFE28K, DFE28, PFD28, PYE22K, PYD22, DYE22

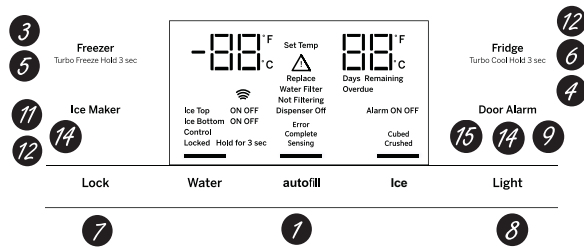

Control Style C, External Controls GFD28, GFE28, GFE26, GFS26, GYE22, GYS22

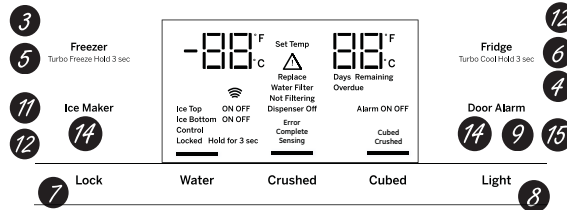

- 1 Hands-free Autofill***
Hands-free Autofill uses sensors to monitor container height to automatically dispense filtered water without having to activate the paddle.
- 2 Start Heating***
The Start Heating button is used to initiate the water heating for the Single Serve feature. To abort the Start Heating feature, press and hold the Start Heat button for 3 seconds.
- 3 Freezer temp control**
Adjust freezer compartment temperature.
- 4 Refrigerator temp control**
Adjust refrigerator compartment temperature.
- 5 TurboFreeze™ setting**
Activate **TurboFreeze** to quickly restore freezer temperatures after frequent door openings.
- 6 TurboCool™ setting**
Activate **TurboCool** to quickly restore refrigerator temperature after frequent door openings.
- 7 Lock Controls**
Control Style A - Press and hold the **Door Alarm** pad for 3 seconds to lock out ice and water dispenser and all feature and temperature buttons.
Control Styles B & C - Press **Lock** pad and hold 3 seconds to lock out ice and water dispenser and all feature and temperature buttons.
- 8 Dispenser light**
Lighting that can be turned on/off to light your dispenser.
- 9 Door Alarm**
Sounds to alert when the freezer or refrigerator doors have been left open. Press and hold **Door Alarm** pad and it will toggle the sound between low, high, and off.
- 10 Brew Size***
The Brew Size button is used to select the desired cup size for single serve. Press and hold the button for 3 seconds to toggle the brew type between **Coffee** and **Cocoa**.
- 11 Ice maker setting**
Turn your ice makers on/off.
- 12 Cooling system On/Off**
Control Style A - Press and hold **Freezer** and **Start Heating** simultaneously to turn cooling system off. To turn cooling system on press either the **Fridge** or **Freezer**.
Control Style B & C - Press and hold **Fridge** and **Ice Maker** simultaneously for 3 seconds to turn the cooling system off. To turn cooling system on press either the **Fridge** or **Freezer**.
- 13 Brew Dispense**
Press and hold **Brew Dispense** button for 3 seconds, but no longer than 6 seconds, to dispense coffee or cocoa.
- 14 F°/C°**
Control Style A - Press and hold **Freezer** and **Brew Size** to switch between F°/C°.
Control Style B & C - Press and hold **Ice Maker** and **Door Alarm** simultaneously for 3 seconds to switch between F°/C°.
- 15 Sound Control for pad chimes**
Control Style A - Press and hold the **Light** pad: Once for High to Off, twice for Off to Low and three times for Low to High.
Control Styles B & C - Press and hold the **Door Alarm** pad: Once for High to Off, twice for Off to Low and three times for Low to High.
- 16 High Altitude**
Control Style A (PYE and PFE only) - Press and hold **Fridge** and **Door Alarm** for to toggle between Hi AL and Lo AL for high altitude and low altitude.

Additional settings:

- Connected Home ready* (PFE28P, PYE22P, PFH only)
- Water Filter* - An indicator will illuminate when the filter needs to be replaced. When a new filter is installed the indicator will go off.

Additional Mode:

- **Sabbath Mode**
Control Style A - Press and hold **Alarm** and **Light** simultaneously for 3 seconds to enter/exit Sabbath mode.
Control Style B & C - Press and hold **Lock** and **Light** simultaneously for 3 seconds to enter/exit Sabbath mode. Sabbath Mode will turn off or dim interior lights, temperature control and advanced features. Compressor will run on a timed defrost when in Sabbath mode.

*Select Models Only

Controls

Controls Style D, Internal Controls GNE29, GWE23, PWE23

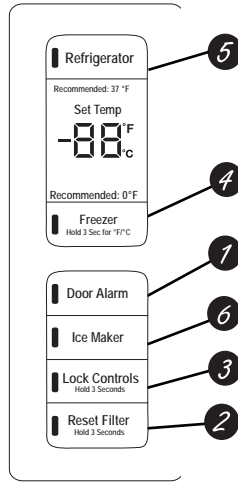

- 1 Door Alarm**
Sounds to alert when the freezer or refrigerator doors have been left open.
- 2 Reset Filter**
Hold for 3 seconds after replacing filter.
- 3 Lock Controls**
Press and hold 3 seconds to lock out ice and water dispenser and all feature and temperature buttons.

- 4 Freezer temp control**
Adjust freezer compartment temperature
- 5 Refrigerator temp control**
Adjust refrigerator compartment temperature
- 6 Ice maker setting**
Turn your ice maker on/off.

Additional Mode:

- **Sabbath Mode**
Press and hold **Door Alarm** and **Ice Maker** simultaneously for 3 seconds to enter/exit Sabbath mode.

Dispenser*

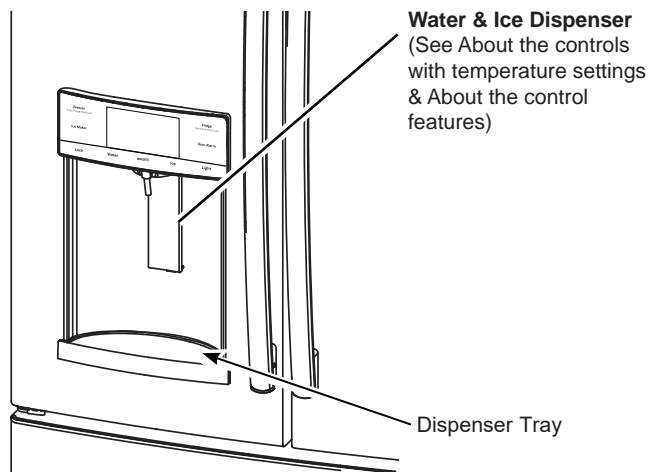

Water & Ice Dispenser
(See About the controls with temperature settings & About the control features)

Dispenser Tray

If no water is dispensed when the refrigerator is first installed, there may be air in the water line system. Press the dispenser paddle for at least five minutes to remove trapped air from the water line and to fill the water system. To flush out impurities in the water line, throw away the first six full glasses of water.

To remove Dispenser Tray (Type A and B Only)

- Pull Dispenser Tray out until it stops.
- Locate tab in the center on the bottom and push up.
- Pull Dispenser Tray assembly out.
- Lift Dispenser Tray out at center notch to clean.

To remove Dispenser Tray (Type C Only)

Grasp Dispenser Tray and pull firmly until it comes out.

To reinstall Dispenser Tray (Type A and B Only)

- Place the Dispenser Tray cover on top of catch tray and position under the two plastic retainers on either side.
- Center Dispenser tray, and align with center guides.
- Push in until it locks firmly in place.

To reinstall Dispenser Tray (Type C Only)

Line up the guide on tray bottom with track on dispenser and slide it in until it stops against the back of the dispenser.

▲ WARNING Laceration Hazard

- Never put fingers or any other object into ice crusher discharge opening. Doing so can result in contacting the ice crushing blades and lead to serious injury or amputation
- Use a sturdy glass when dispensing ice. A delicate glass may break and result in personal injury.

Important Facts About Your Dispenser

- Do not add ice from trays or bags to the door ice maker bucket. It may not crush or dispense.
- Avoid overfilling glass with ice and use of narrow glasses. Backed-up ice can jam the chute or cause the door in the chute to freeze shut. If ice is blocking the chute remove the ice bucket, poke it through with a wooden spoon.
- Beverages and foods should not be quick-chilled in the door ice maker bin. Cans, bottles or food packages in the storage drawer may cause the ice maker or auger to jam.
- To keep dispensed ice from missing the glass, put the glass close to, but not touching, the dispenser opening.
- Some crushed ice may be dispensed even though you selected **CUBED ICE**. This happens occasionally when a few cubes accidentally get directed to the crusher.
- After crushed ice is dispensed, some water may drip from the chute.
- Sometimes a small mound of snow will form on the door in the ice chute. This condition is normal and usually occurs when you have dispensed crushed ice repeatedly. The snow will eventually evaporate.

To Use the Internal Water Dispenser*

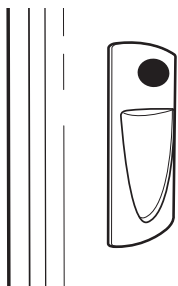

The water dispenser is located on the left wall inside the refrigerator compartment.

To dispense water:

- 1 Hold the glass against the recess.
- 2 Push the water dispenser button.
- 3 Hold the glass underneath the dispenser for 2–3 seconds after releasing the dispenser button. Water may continue to dispense after the button is released.

If no water is dispensed when the refrigerator is first installed, there may be air in the water line system. Press the dispenser button for at least 5 minutes to remove trapped air from the water line and to fill the water system. During this process, the dispenser noise may be loud as the air is purged from the water line system. To flush out impurities in the water line, throw away the first 6 glassfuls of water.

NOTE: To avoid water deposits, the dispenser should be cleaned periodically by wiping with a clean cloth or sponge.

*Select Models Only

AUTOFILL*

To Use HANDS FREE AUTOFILL:

- Center container on Recess Dispenser Tray as far back as possible without activating paddle and remove hand from container
- Press **AUTOFILL**

To Stop AUTOFILL

- Press **AUTOFILL** to stop.

Important Facts about AUTOFILL

- For optimum results, use a uniform container between 4-8" (10-20 cm) tall and 2-6" (5-15 cm) wide.
- Fill level and functionality may vary on containers taller than 8" (20 cm) or wider than 6" (15 cm).
- Container volumes may vary, if error message "Not Found" is given, try a different container.
- AUTOFILL will time out.
- Handles, straws, and garnishes on the rim of the container may cause overflowing or variation in fill volumes.
- Splashing may occur depending on the location of the container, water flow rate, container shape, and ice cubes.
- Keep sensors clean with a clean damp cloth, and do not spray liquid or cleaners directly on sensors
- AUTOFILL works best with household water pressure of 60 to 100 psi (414 to 689 kPa).
- Ice in container may affect fill volume. If issues are experienced, use less ice.

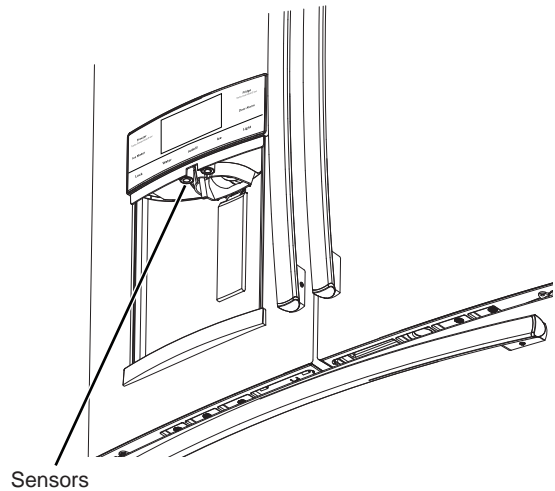

Single Serve Keurig K-Cup Brewer*

Important Facts about HOT WATER

▲ WARNING



Scalding Hazard.

- The water coming from the dispenser is very hot and can cause scalds or burns. **Read all warnings on page 5 prior to use.**
- Do not permit children to use the brewer.
- Always use a container that is suitable for hot liquids (ceramic, foam, etc.)
- Do not brew into a mug made of glass. Doing so may cause the glass to crack or break.
- If you live above 5000 feet (1524 meters), press **Fridge** and **Door Alarm** and control will cycle from Low Altitude (Lo AL) to High Altitude (Hi AL).
- **DO NOT** use the hot water dispenser immediately after installing a new water filter as it may result in spurting of hot water. Dispense cold water for about 5 minutes to purge air from the system prior to dispensing hot water.

*Select Models Only

Single Serve Keurig K-Cup Brewer* (Cont.)

How to use the single serve dispenser

- 1 Load the K-Cup Brewer**
 Insert a Keurig K-Cup pod into the brewer and press down firmly (you will hear a popping sound).

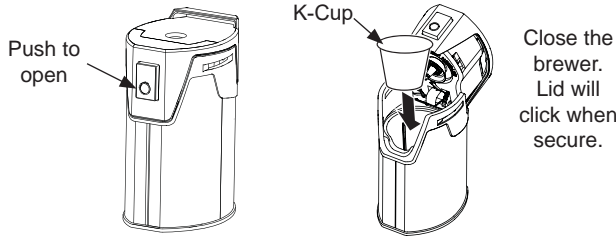

▲ CAUTION	Cut/Puncture Hazard.
<ul style="list-style-type: none"> • There are two sharp needles located inside the K-Cup brewer. To avoid risk of injury, do not put your fingers inside the brewer. Use caution when cleaning. • Keep the K-Cup brewer out of the reach of children, as they may be injured in using the K-Cup brewer incorrectly. 	

- 2 Two Ways To Brew**
1. Press the **Start Heating** button.
- OR
2. Initiate heating with the GE Kitchen App. Download the App "GE Kitchen". Visit GEAppliances.com/connect for more information.**

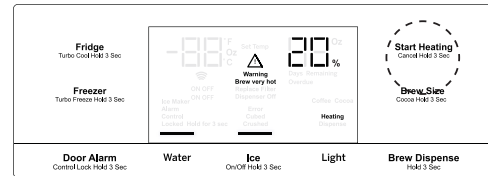

- 3 Change Brew Size**
- Press the **Brew Size** button any time during the heating cycle to choose 6, 8, or 10 oz. The default size is 8 oz. Ensure the mug being used is large enough for the size selected.
- NOTE:** Press and hold the **Brew Size** button for 3 seconds to toggle between Coffee and Cocoa. The default is **Coffee**.

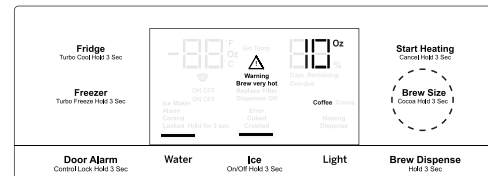

- NOTE:** To abort the heating cycle, press and hold the **Start Heating** button for 3 seconds. To abort the brew dispense cycle, press and hold the **Start Heating** button for 3 seconds, press the paddle, press any button on the display besides **Brew Size** or **Brew Dispense**, or open the right refrigerator door.

- 4 Dispense**
- Once the heating process is complete, the Dispense light on the display will flash.
- To dispense, slide the brewer into the rails. Make sure the brewer is pushed all the way into the bracket. Place your mug on the drip tray mug icon, under the red brew spout. Press and hold **Brew Dispense** for 3 seconds until you hear the dispenser engage.

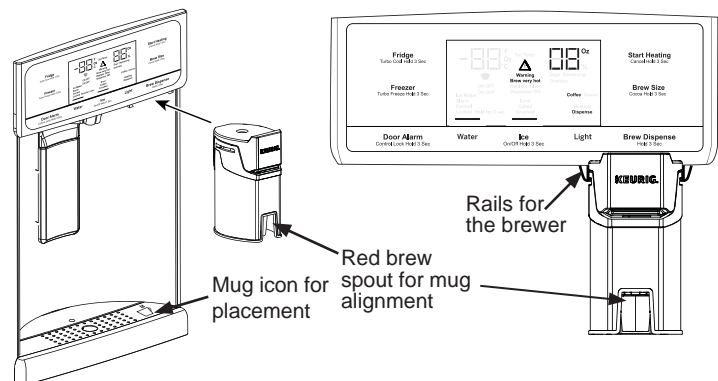

Cleaning the brewer

- The K-Cup brewer is top rack dishwasher safe.
- It is recommended to rinse it thoroughly after washing to remove all soap residue.
- Periodic cleaning of dispenser recess area is recommended as staining may occur with usage of the K-Cup brewer.

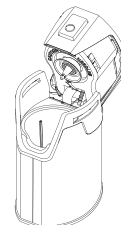

*Select Models Only ** For US and US Territories Only.

Appliance Communication

GE WiFi Connect**

(for customers in the United States, its territories, and Canada)

GE WiFi Connect Enabled* (PFE28P, PFD28, PYD22, PYE22P, PFH models only)

If your refrigerator has a Connected Appliance information label located on the inside as shown, your refrigerator can be connected to your WiFi network, allowing it to communicate with your smart phone for remote monitoring, control and notifications. Depending on the refrigerator model you have, you either have a WiFi communication card built into the product, or a port for an external WiFi ConnectPlus Module (sold separately).

Please visit GEAppliances.com/connect to learn more about connected appliance features, and to learn what connected appliance apps will work with your Smart Phone.**

To use your WiFi, press **Water** and **Light** on the control panel.

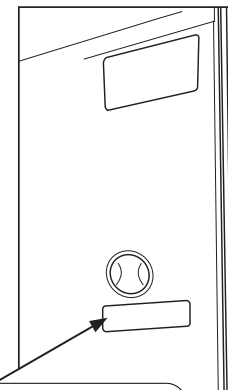

Connected Appliance Information	
Contains FCCID: ZKJ-WCATA003	Network: GE_MODULE_XXXX
Contains IC: 10229A-WCATA003	Password: XXXXXXXXX
MAC ID: D8-28-C9-XXXXXXXX	PT. NO. 257C2110G001

GE WiFi Connect Optional *

Your refrigerator is **GE WiFi Connect** compatible using the **GE ConnectPlus** module that is provided with your refrigerator. To connect this appliance to the internet you will need to attach the module to your appliance through the communication port in the appliance. The **GE ConnectPlus** will allow your appliance to communicate with your smart phone for remote appliance monitoring, control and notifications. Please visit GEAppliances.com/connect to learn more about connected appliance features, to learn what connected appliance App's will work with your Smart Phone and to learn where you can purchase a **GE ConnectPlus**.**

WiFi Connectivity: For assistance with the appliance or the **ConnectPlus** network connectivity (for models that are WiFi enabled or WiFi optional), please call **1-800-220-6899**.

REGULATORY INFORMATION

FCC/IC Compliance Statement:

This device complies with Part 15 of the FCC Rules. Operation is subject to the following two conditions:

1. This device may not cause harmful interference.
2. This device must accept any interference received, including interference that may cause undesired operation.

This equipment has been tested and found to comply with the limits for a Class B digital device, pursuant to Part 15 of the FCC Rules. These limits are designed to provide reasonable protection against harmful interference in a residential installation. This equipment generates uses and can radiate radio frequency energy and, if not installed and used in accordance with the instructions, may cause harmful interference to radio communications. However, there is no guarantee that interference will not occur in a particular installation. If this equipment does cause harmful interference to radio or television reception, which can be determined by turning the equipment off and on, the user is encouraged to try to correct the interference by one or more of the following measures:

- Reorient or relocate the receiving antenna.
- Increase the separation between the equipment and receiver.
- Connect the equipment into an outlet on a circuit different from that to which the receiver is connected.
- Consult the dealer or an experienced radio/television technician for help.

Labelling: Changes or modifications to this unit not expressly approved by the manufacturer could void the user's authority to operate the equipment.

ConnectPlus module only (or similar communication module)

RF Exposure - This device is only authorized for use in a mobile application. At least 20 cm of separation distance between the **ConnectPlus** device and the user's body must be maintained at all times.

*Select Models Only

** For US, US Territories and Canada Only.

Water Filter Cartridge - RPWFE

Water Filter Cartridge

The water filter cartridge is located in the fresh food interior on the left side wall, near the top.

Select models use radio frequency identification (RFID) to detect leaks and monitor filter status. The RFID technology is certified by the FCC.

“This device complies with part 15 of the FCC Rules. Operation is subject to the following two conditions: (1) This device may not cause harmful interference, and (2) this device must accept any interference received, including interference that may cause undesired operation.”

“This device complies with Industry Canada licence-exempt RSS standard(s). Operation is subject to the following two conditions: (1) this device may not cause interference, and (2) this device must accept any interference, including interference that may cause undesired operation of the device.”

When to Replace the Filter Cartridge

The filter cartridge should be replaced every six months or earlier if 170 gallons (643.52 liters) of water has been dispensed or the flow of water to the dispenser or icemaker decreases.

Touch Screen Models: A filter status message will appear on the screen when the water filter needs to be replaced. The filter status will automatically update when the filter is replaced.

Non-touch Screen Models: A filter indicator light will illuminate on the screen when the water filter needs to be replaced.

On some models, if replacing the filter does not automatically turn off the replace filter indicator on the display, press and hold the water button for 3 seconds until you see the “Replace Water Filter” indicator and hear the tone, which indicates the filter has been reset.

Removing the Filter Cartridge

DO NOT TWIST CARTRIDGE! Twisting may damage refrigerator or filter.

1. Remove the old cartridge by opening the filter door and pulling on the bottom of the cartridge to allow it to swing outward.
2. When the cartridge can no longer swing, gently pull to unseat from the cartridge holder. A small amount of water may drip out.

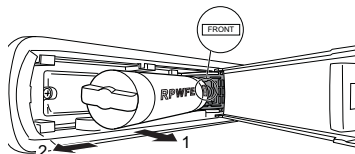

DO NOT TWIST CARTRIDGE!

Installing the Filter Cartridge

1. Center the cartridge with cartridge holder with the word **FRONT** facing outward. Push the cartridge inward until it is fully seated. **FRONT** should be centered with the cartridge holder for proper installation. The RED indicators should not be visible.

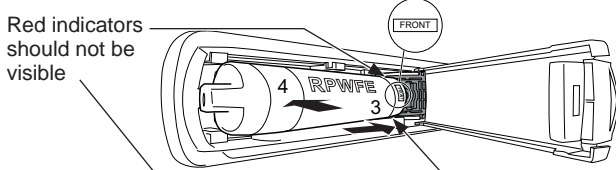

2. While continuing to ensure cartridge is fully seated in the

holder, gently swing the filter inward until it is in position. If filter will not swing easily, check to ensure filter is properly aligned and fully seated within the cartridge holder.

3. **For dispenser models** – Run 2 gallons of water through the cold water dispenser (about 5 minutes) to remove air from the system. A newly installed filter cartridge will cause water to spurt from the dispenser. Use a large pitcher or sports bottle to catch the water spray. **NOTE:** It is normal for water to appear discolored during the initial system flush. Water color will return to normal after the first few minutes of dispensing.

For icemaker-only models – Discard the first bin of ice to allow air to purge from the system. A newly installed filter cartridge will cause water to spurt into the icemaker body, which could lead to ice droplets around the icemaker area. **NOTE:** It is normal for these droplets and initial ice production to appear discolored during the initial system flush. Ice color will return to normal after the first bin of ice production.

DO NOT use the hot water dispenser or Autofill function until all air is removed from the system.

6. Reset Filter status message (non-touch screen models).

Filter Bypass Plug

To reduce the risk of property damage due to water leakage, you **MUST** use the filter bypass plug when a replacement filter cartridge is not available. Some models do not come equipped with the filter bypass plug. To obtain a free bypass plug, visit us on-line at geappliances.com/service. In Canada, visit geappliances.ca/service. The dispenser and icemaker will not operate without either the filter or the bypass plug installed. The bypass plug is installed in the same way as a filter cartridge.

▲ WARNING  **SCALDING HAZARD.***

Use of the hot water dispenser prior to purging air from the system may result in spurting of hot water and lead to hot water scalding. Follow the instructions above to purge all air from the system through the cold water dispenser prior to using the hot water dispenser.

*On some models

▲ WARNING To reduce the risk associated with choking, do not allow children under 3 years of age to have access to small parts during the installation of this product. The disposable filter cartridge should be replaced every 6 months at the rated capacity, or sooner if a noticeable reduction in flow rate occurs.

For the maximum benefit of your filtration system, GE Appliances, a Haier company, recommends the use of GE Appliances-branded filters only. Using GE Appliances-branded filters in GE Appliances refrigerators provides optimal performance and reliability. Our filters meet rigorous industry NSF standards for safety and quality that are important for products that are filtering your water. There is no assurance that brands other than GE Appliances filters meet our standards for quality, performance and reliability.

If you have questions, or to order additional filter cartridges, visit gewaterfilters.com. In Canada, visit GEAppliances.ca/service or consult the yellow pages for the nearest Camco Service Center.

Refrigerator Storage Options

Rearranging the Shelves

Shelves in the refrigerator compartment are adjustable.

To remove:

- 1 Remove all items from the shelf.
- 2 Tilt the shelf up at the front.
- 3 Lift the shelf up at the back and bring the shelf out.

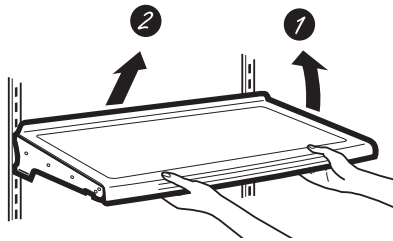

To replace:

- 1 While tilting the shelf up, insert the top hook at the back of the shelf in a slot on the track.
- 2 Lower the front of the shelf until the bottom of the shelf locks into place.

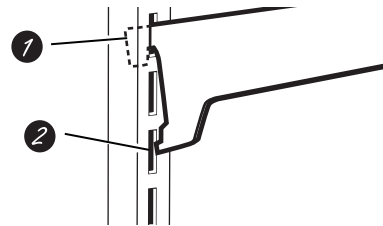

Spillproof Shelves

Spillproof shelves have special edges to help prevent spills from dripping to lower shelves.

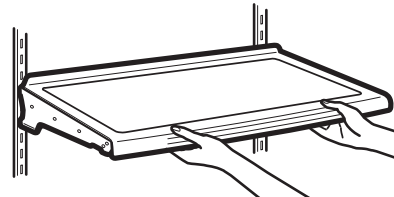

Quick Space Shelf *

This shelf splits in half and slides under itself for storage of tall items on the shelf below.

This shelf can be removed and replaced or relocated (just like spillproof shelves).

NOTE: The back half of the Quick Space Shelf is not adjustable.

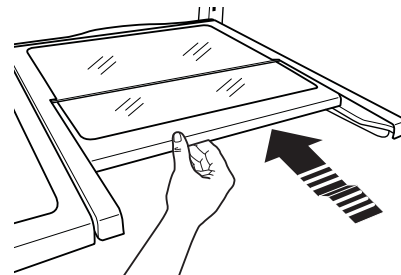

*Select Models Only

Refrigerator Storage Options

Right Door Bins

FIXED BINS can easily be carried from refrigerator to work area.

To remove: Lift bin straight up, then pull out.

ROTATING BIN*:

To remove: Rotate bin outward then lift straight up. To remove Place hand under metal base and lift up.

To remove Metal Base: Place hand under metal base and lift up.

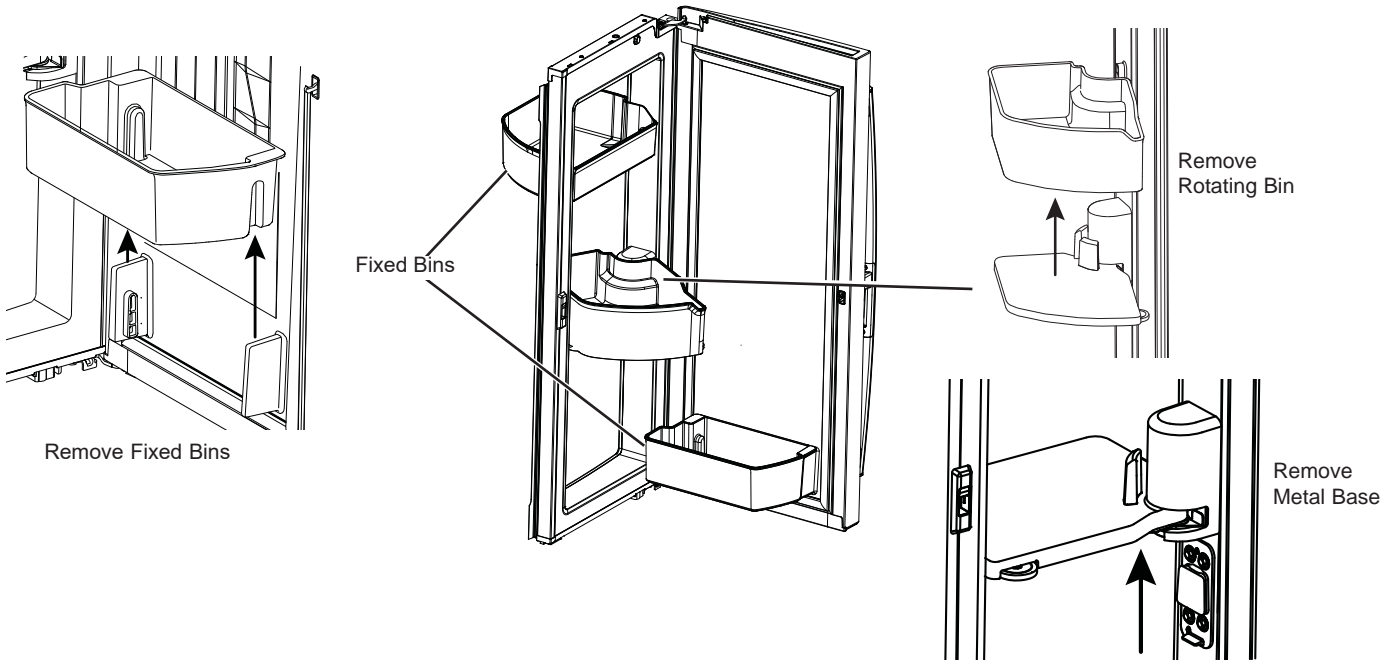

Left Door Bins

DISPENSER MODELS - FIXED BIN

To remove: Lift the bin straight up, then pull out.

The ice maker door bins are not interchangeable, note the location upon removal and replace the bin in its proper location.

NON-DISPENSER MODELS - ADJUSTABLE BINS*

Adjustable bins can easily moved up or down the inside of the door to give better flexibility for storage.

To remove: Lift bin straight up, then pull out.

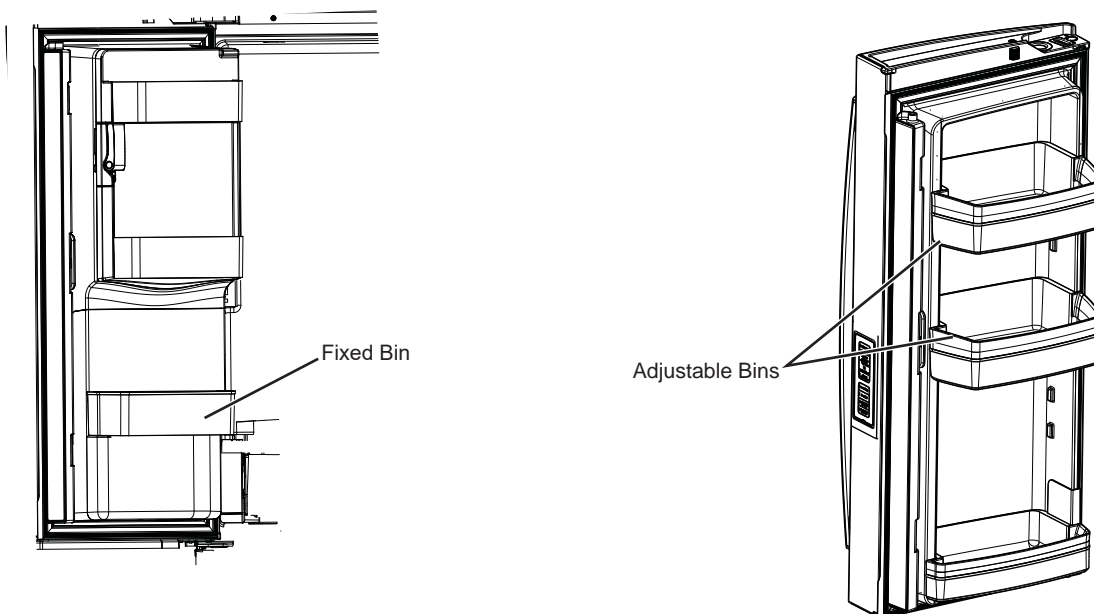

*Select Models Only

Climate Zone & Temperature Controlled Drawer

ClimateZone

Keep fruits and vegetables organized in separate compartments for easy access.

Excess water that may accumulate in the bottom of the drawers or under the drawers should be wiped dry.

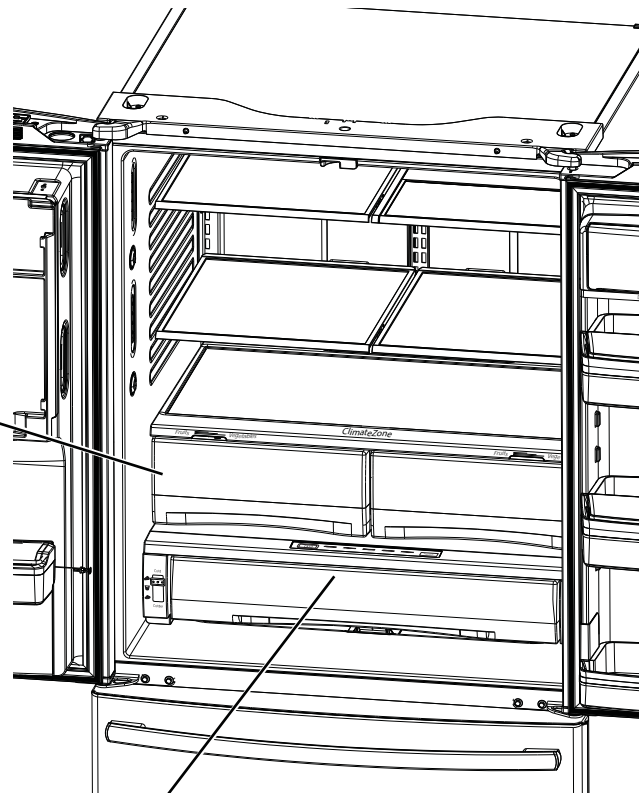
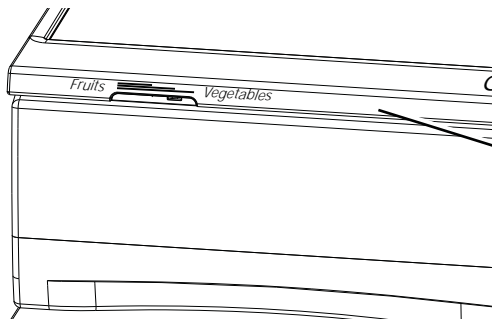

Temperature Controlled Drawer*

The Temperature Controlled Drawer is a full-width drawer with adjustable temperature control. This drawer can be used for large miscellaneous items.

To change setting, press select button.

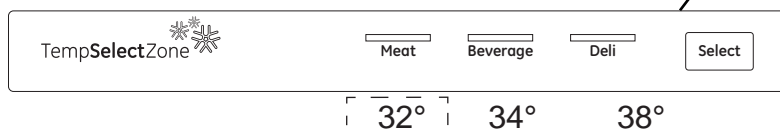

Note: Temperatures indicate the appropriate temperatures for the food and actual temperatures may vary based on normal operation and other factors such as door openings and refrigerator set point.

⚠ CAUTION Laceration Hazard.
Do not store glass bottles at this setting. If they are frozen, they can break and result in personal injury.

*Select Models Only

Climate Zone & Temperature Controlled Drawer

How to Remove and Replace Drawer

To remove:

- 1 Pull the drawer out to the stop position.
- 2 Lift the front of the drawer up and out.

To replace:

- 1 Pull left and right slides until fully extended.
- 2 Place drawer back in first and rotate drawer front down to seat on slide.
- 3 Push the drawer in to closed position.

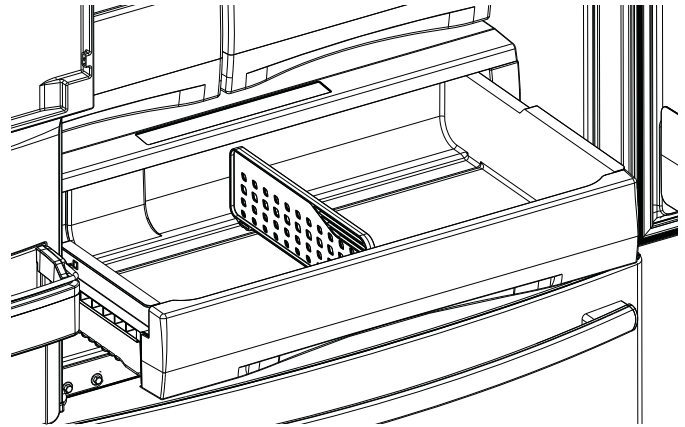

How to Remove and Replace Drawer Divider*

To remove:

- 1 Pull the drawer out to the stop position.
- 2 Raise the front side of the divider to unhook it from the rear wall of the drawer.

To replace:

- 1 Hook the back of the divider over the rear wall of the drawer.
- 2 Push the divider down.

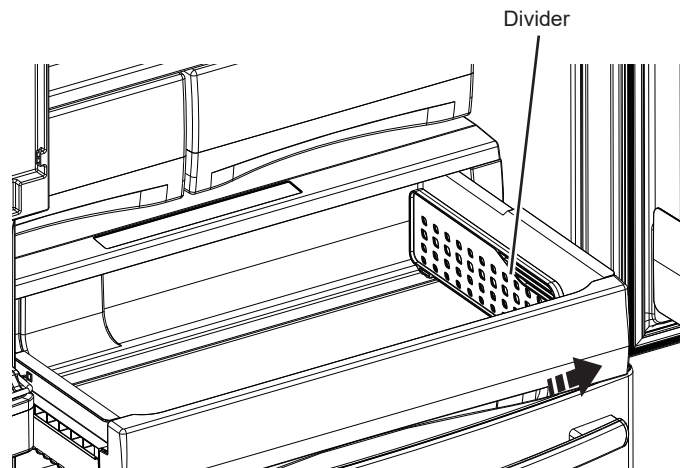

*Select Models Only

Baskets, Drawers, and Bins

Freezer Basket and Drawer

- ① Basket.
- ② Drawer
- ③ Ice Bucket * (Available on Non-Dispense models only. Available as a IM Kit on some models)

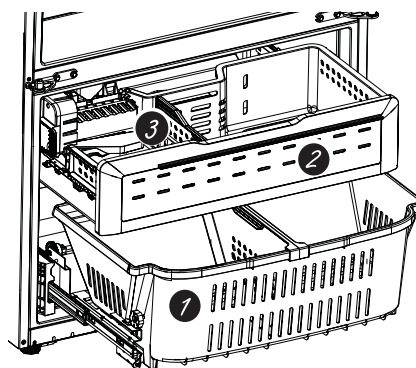

Non-Adjustable Bin in the Freezer*

To remove:

Push in plastic tab on either left or right side

To replace:

Slide bin into location until it locks into place.

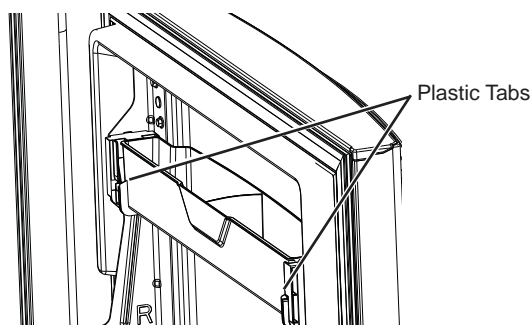

Basket Removal

To remove, standard depth models only:

1. Open freezer door to the stop position.
2. Remove freezer door bin by pushing plastic tab on either left or right side to release bin hinge pin.
3. Remove freezer basket by lifting up the rear of the basket and moving basket rearward until the front of the basket can be rotated upward and out.
4. Lift it out to remove.

To remove, counter depth models only:

1. Open refrigerator doors.
2. Open freezer door to the stop position.
3. Remove freezer basket by lifting up the rear of the basket and rotate it upward.
4. Lift it out to remove.

To replace:

Reverse step 1 through 4 to replace.

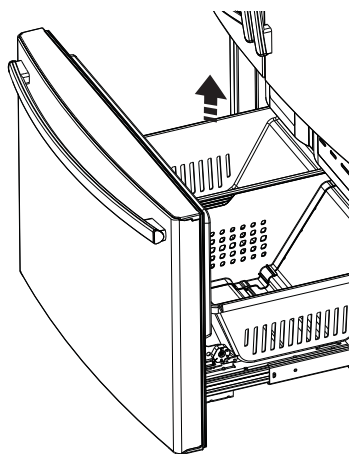

*Select Models Only

Automatic Ice Maker

A newly installed refrigerator may take 12 to 24 hours to begin making ice.

⚠ WARNING Connect to potable water supply only.
 A cold water supply is required for automatic icemaker operation. The water pressure must be between 40 and 120 psi (275-827 kilopascals).

Automatic Ice maker*

The ice maker will produce seven cubes per cycle approximately 100–130 cubes in a 24-hour period, depending on freezer compartment temperature, room temperature, number of door openings and other use conditions.

The ice maker will fill with water when it cools to 15°F (-10°C). A newly installed refrigerator may take 12 to 24 hours to begin making ice cubes.

If the refrigerator is operated before the water line connection is made to the unit or if the water supply to an operating refrigerator is turned off, make sure that the ice maker is turned off. Once the water has been connected to the refrigerator, the ice maker may be turned on. See the table below for details.

You may hear a buzzing sound each time the ice maker fills with water.

Throw away the first bin of ice to allow the water line to clear. It is normal for ice to appear discolored in the first 24 hours of production, or after water filter replacement.

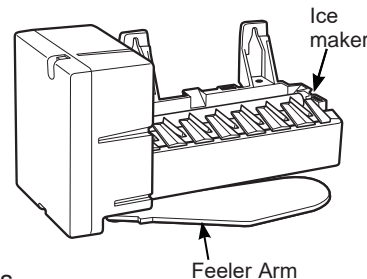

Be sure nothing interferes with the sweep of the feeler arm.

When the bin fills to the level of the feeler arm, the ice maker will stop producing ice. It is normal for several cubes to be joined together.

If ice is not used frequently, old ice cubes will become cloudy, taste stale and shrink.

NOTE: In homes with lower-than-average water pressure, you may hear the ice maker cycle multiple times when making one batch of ice.

⚠ CAUTION To minimize the risk of personal injury, avoid contact with the moving parts of the ejector mechanism, or with the heating element that releases the cubes. Do not place fingers or hands on the automatic ice making mechanism while the refrigerator is plugged in.

How to Turn the Ice Maker On/Off

Display Type (See Page 8)	Model #	How to turn the ice maker on/off
Control Style A	PFE28P, PYE22P	Use the "ICE" button on the control. See Controls , pages 10 & 11.
Control Style B, C	PFH28, PFE28K, PFD28, DFE28, GFE28, GFD28, GFE26, GFS26, PYD22, PYE22K, DYE22K, GYE22, GYS22	Use the "ICE MAKER" button on the control. See Controls , pages 10 & 11.
Control Style D	GNE29, GWE23, PWE23	Use the "ICE MAKER" button on the control. See Controls , pages 10 & 11.

Ice Bucket and Dispenser*

- Open the ice box door on inside of the left door.
- Pull up and out on the ice bucket in the left hand door to remove it from the compartment.
- To replace the ice bucket, set it on the guide brackets and push until the ice bucket seats properly.
- If bucket cannot be replaced, rotate the ice bucket fork 1/4 turn clockwise.

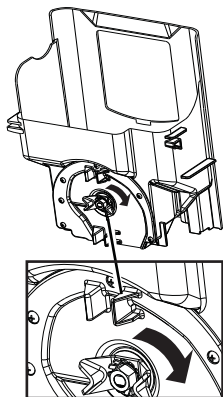
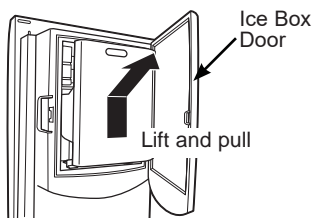

Ice Maker (Available on Non Dispense models, also available as IM Kit for some models)

There is additional ice storage in the freezer compartment drawer.

- Open the freezer drawer.
- The ice bucket is located on the left side of the upper basket.
- Pull the upper basket forward to remove the ice bucket.

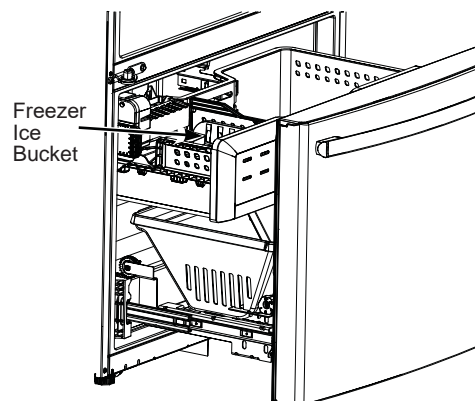

*Select Models Only

Care and Cleaning

Cleaning the Outside

FINGERPRINT RESISTANT STAINLESS STEEL*, BLACK STAINLESS, SLATE, DARK SLATE, PAINTED - Outside surfaces, door handles, and trim

⚠ DO NOT use Stainless Steel cleaners on the door surfaces. ⚠

IMPORTANT: The use of incorrect products may damage the outer finish of Fingerprint Resistant Stainless and Black Stainless models. Please follow these instructions and use only the appropriate items below to clean your appliance surfaces.

- Clean interior/exterior surfaces with warm water, mild soap or detergent, and a soft or microfiber cloth to avoid damage.
- Wipe the appliance surface dry with a soft clean cloth or microfiber towel to avoid streaking or water spotting.

DO USE	DO NOT USE
Soft, clean cloth or sponge Microfiber cloth	Abrasive cloths, paper towels, scrubbing sponges (with or without soap), scouring or steel wool pads
Mild detergent mixed with warm water	Abrasive powders, liquids, or sprays Window sprays, ammonia, or bleach Citrus or plant oil-based cleaners Acidic or vinegar-based cleaners Oven cleaners Alkaline cleaners Stainless steel cleaners

*Easily wipe away smudges and fingerprints.

STAINLESS STEEL - Outside surfaces, door handles, and trim

NOTE: DO NOT allow stainless steel cleaner to come in contact with any plastic parts such as trim pieces, handle hardware and liners. If unintentional contact of cleaners with plastic parts does occur, clean plastic part with a sponge and mild detergent mixed with warm water.

DO USE	DO NOT USE
Soft, clean cloth or sponge	Abrasive cloths, scrubbing sponges (with or without soap), scouring or steel wool pads
Mild detergent mixed with warm water Approved stainless steel cleaners; Visit the GE Appliances parts store for approved stainless steel cleaners: GEApplianceparts.com or call 877.959.8688 Cleaners with oxalic acid such as Bar Keepers Friend Soft Cleanser™ can be used to remove surface rust, tarnish and small blemishes on stainless steel surfaces only.	Abrasive powders or sprays Window Sprays or Ammonia Citrus or plant oil-based cleaners Acidic or vinegar-based cleaners Oven cleaners Cleaners containing acetone (propanone) Any cleaner with WARNING about plastic contact

Cleaning the Inside

To help prevent odors, leave an open box of baking soda in the refrigerator and freezer compartments.

Unplug the refrigerator before cleaning.

If this is not practical, wring excess moisture out of sponge or cloth when cleaning around switches, lights or controls.

Use an appliance wax polish on the inside surface between the doors.

Use warm water and baking soda solution—about a tablespoon (15 ml) of baking soda to a quart (1 liter) of water. This both cleans and neutralizes odors. Rinse and wipe dry.

To clean the inside metal panel*, open the outer door using the Door in Door Latch. Clean the panel with a mild detergent and then wipe dry with a soft cloth. Do not use any stainless steel cleaner on the panel as it may damage the surrounding plastic.

⚠ CAUTION Do not clean glass shelves or covers with warm water when they are cold. Glass shelves and covers may break if exposed to sudden temperature changes or impact such as bumping or dropping. Tempered glass is designed to shatter into many small pieces if it breaks.

Do not wash any plastic refrigerator parts in the dishwasher.

Care and Cleaning

Behind the Refrigerator

Be careful when moving the refrigerator away from the wall. All types of floor coverings can be damaged, particularly cushioned coverings and those with embossed surfaces.

Raise the leveling legs located at the bottom front of the refrigerator.

Pull the refrigerator straight out and return it to position by pushing it straight in. Moving the refrigerator in a side direction may result in damage to the floor covering or refrigerator.

Lower the leveling legs until they touch the floor.

⚠ WARNING  **ELECTRICAL SHOCK HAZARD**

When pushing the refrigerator back, make sure you don't roll over the power cord or water supply line.

Preparing for Vacation

For long vacations or absences, remove food and unplug the refrigerator. Clean the interior with a baking soda solution of one tablespoon (15 ml) of baking soda to one quart (1 liter) of water. Leave the doors open.

If the temperature can drop below freezing, have a qualified service technician drain the water supply system to prevent serious property damage due to flooding.

1. Turn refrigerator off or unplug the refrigerator.
2. Empty ice bucket
3. Turn water supply off

If you cut the water supply off, turn off the ice maker.

Upon returning from vacation:

1. Replace the water filter.
2. Run 2 gallons (7.57 liters) of water through the cold water dispenser (about 5 minutes) to flush the system.

Preparing to Move

Secure all loose items such as shelves and drawers by taping them securely in place to prevent damage.

When using a hand truck to move the refrigerator, do not rest the front or back of the refrigerator against the hand truck. This could damage the refrigerator.

Handle only from the sides of the refrigerator.

Be sure the refrigerator stays in an upright position during moving.

Replacing the Lights

Refrigerator Lights (LEDs)

Appearance may vary by model.

There is LED lighting in refrigerator compartment and on the bottom of the refrigerator doors to light the freezer compartment.*

An authorized technician will need to replace the LED light.

If this assembly needs to be replaced, call GE Appliances Service at 1.800.432.2737 in the United States or 1.800.561.3344 in Canada.

